

# Elite

BY MAXI-MATIC

# PLATINUM

## 4 QT. DIGITAL PRESSURE COOKER

MODEL: EPC-414(A~Z)

### INSTRUCTION MANUAL

Before operating your new appliance, please read all instructions carefully and keep for future reference.



Questions? Elite's customer service team is ready to help. Call us toll-free at 800-365-6133 ext. 120/107/105. For more Elite products, visit us at [www.maxi-matic.com](http://www.maxi-matic.com). Recipes are included in this manual.

## IMPORTANT SAFEGUARDS

When using pressure cookers, basic safety precautions should always be followed:

1. Read all instructions before operation.
2. Do not touch hot surfaces. Use handles or knobs and a potholder.
3. This appliance should not be used by or near children or individuals with certain disabilities.
4. **NEVER ATTEMPT TO OPEN LID WHILE THE UNIT IS OPERATING.** Do not open the pressure cooker until the unit has cooled and all internal pressure has been released. If lid is difficult to rotate, this indicates that the cooker is still pressurized. Do not force it to open. Any pressure in the cooker can be hazardous. See "OPERATING INSTRUCTIONS" section in this manual.
5. Do not place the pressure cooker in a heated oven or on any stovetop.
6. Extreme caution must be used when moving a pressure cooker containing hot liquids.
7. Do not use pressure cooker for other than intended use.
8. This appliance cooks under pressure. Improper use may result in scalding injury. Make certain unit is properly closed before operating. See "INSTRUCTIONS FOR USE" section in this manual.
9. To protect against electrical shock, do not immerse cord, plugs, or outer vessel in water or other liquids.
10. Do not fill unit over 2/3 full. When cooking foods that expand during cooking such as rice, legumes, beans, or dried vegetables, do not fill the unit over 1/2 full. Overfilling may cause a risk of clogging the pressure limiting valve and developing excess pressure. Failure to follow this procedure can result in injury to person(s) and/or damage to the unit. See "INSTRUCTIONS FOR USE" section in this manual.
11. Be aware that certain foods, such as applesauce, cranberries, pearl barley, oatmeal or other cereals, split peas, noodles, macaroni, rhubarb, or spaghetti can foam, froth, and sputter, and clog the pressure release device (steam vent). These foods should not be cooked in a pressure cooker unless following a Maxi-Matic® approved pressure cooker recipe.
12. Always check the pressure release devices for clogging before use.
13. Do not use this pressure cooker for pressure frying oil.
14. DO NOT tamper with the Steel Ring in the Lid (2) with any tools or external forces. If the Steel Ring is damaged, please stop using immediately and replace the Lid.
15. Clean the Filter (17) regularly to keep the cooker clean.
16. NEVER use additional weight on the Pressure Limiting Valve (3) or replace the Pressure Limiting Valve (3) with anything not intended for use with this unit.
17. The surface of contact between the Inner Pot (6) and the Electronic Heating Plate (14) should always be clean. DO NOT use the Inner Pot with other heating sources. DO NOT replace the Inner Pot with a container other than what is recommended by the manufacturer.
18. The Inner Pot consists of a non-stick layer surface. To avoid scratching the non-stick surface, please use wooden or plastic utensils.
19. Unplug from outlet when not in use and before cleaning. Allow to cool before putting on or removing parts.
20. Do not operate this appliance with a damaged cord or plug or after it malfunctions or has been damaged in any manner. Return appliance to the nearest authorized service facility for examination, repair or electrical or mechanical adjustment.
21. Always attach plug to appliance first, then plug cord into the wall outlet. To disconnect, turn control to off, then remove plug from wall outlet.
22. Do not use outdoors.
23. The use of accessories not specifically recommended by Maxi-Matic® may cause injuries or damage to the unit.
24. Some countertop and table surfaces, such as Corian®, wood and / or laminates, are not designed to withstand prolonged heat generated by certain appliances. It is recommended

## IMPORTANT SAFEGUARDS (cont.)

by countertop manufacturers and Maxi-Matic® that a hot pad or trivet be placed under your appliance to prevent possible damage to the surface.

25. Do not use under hanging cabinets; steam from pressure release may cause damage.
26. Do not operate your appliance in an appliance garage or under a wall cabinet. When storing in an appliance garage always unplug the unit from the electrical outlet. Not doing so could create a risk of fire, especially if the appliance touches the walls of the garage or the door touches the unit as it closes.
27. Never move pressure cooker when it is pressurized.

# SAVE THESE INSTRUCTIONS FOR HOUSEHOLD USE ONLY

**GROUNDING INSTRUCTIONS:** This appliance must be grounded. It is equipped with a 3-pronged cord having a grounded plug. The plug must be plugged into an outlet which is properly installed and grounded.

**Warning:** Improper use of the grounded cord can result in the risk of electric shock. Consult a qualified electrician if necessary. Do not attempt to defeat this safety feature by modifying plug.

A short power-supply cord is provided to reduce the hazards resulting from entanglement or tripping over a longer cord. If it is necessary to use an extension cord, it should be positioned such that it does not drape over the counter or tabletop where it can be pulled on by children or tripped over and:

- A. Use only 3-pronged extension cord with 3-blade grounding plug.
- B. The marked rating of the extension cord must be equal to or greater than the rating of this appliance. The electrical rating is listed on the bottom of this unit.

## ABOUT PRESSURE COOKING

This digitally controlled and automatic *Pressure Cooker* uses advanced technology so you and your family can enjoy the benefits of better, faster and healthier cooking. Your Elite Platinum *Pressure Cooker* seals in steam to cook hotter and faster while maintaining important nutrients for healthier meals. Cooking fast and with less water saves vital natural resources and energy! The unit features easy touch-button settings, a countdown timer, and a cooking pot big enough for family gatherings! It's the easiest pressure cooker to use on the market. It may seem like a complicated unit but rest assured, this pressure cooker is simple to use, makes meals quick and easy, and overall it saves you money! Please accept our thanks for purchasing an Elite Platinum *Pressure Cooker* and Enjoy!

## ELECTRICAL SAFETY WARNING

- There is a potential risk of fire, electric shock or injury to persons if the product is not used as instructed. Protection against electric shock is assured only if the main power cord is connected to a properly grounded 120V | 60Hz power receptacle.
- This product is to be used in an indoor environment only and is not intended for commercial use. Dry locations only.
- All parts and accessories for this appliance must be used properly according to the instructions. All parts and accessories must be the original provided from manufacturer. All other parts or accessories that is not intended for use with this appliance is strictly prohibited.
- The use of an extension cord, power adapter or other electric devices is highly not recommended.

## LED ERROR INDICATOR

- If any of the below error codes appear on the pressure cooker display, unplug the power cord and re-plug after 10 minutes. If the error code remains, contact the manufacturer for a replacement part.
- See Troubleshooting #11 on page 21 for instructions regarding an E4 error.

Indicator Code	Problems/Causes
E1	Open Circuit of the Sensor
E2	Short Circuit of the Sensor
E3	Overheating
E4	Signal Switch Malfunction

## TABLE OF CONTENTS

1	important safeguards
3	about pressure cooking
3	electrical safety warning
3	E1 - E4 error indicator
5	parts identification <i>6 - how to use the control panel</i> <i>7 - rubber seal ring assembly/ pressure cooker lid markings</i> <i>8 - pressure limiting valve warning/condensation cup assembly</i> <i>9 - float valve assembly</i>
10	additional safety tips
10	before first use <i>11 - lid assembly/water test</i> <i>11 - lid safety lock system</i>
12	instructions for use
13	operating instructions <i>13 - after selecting a menu button</i> <i>13 - after selecting pressure cook time</i> <i>14 - auto-keep warm feature</i> <i>14 - reset/cancel function</i> <i>14 - removing the lid after cooking</i> <i>15 - adding seasoning or ingredients after pressure cooker</i> <i>15 - preparing white rice</i> <i>16 - how to brown/sauté</i> <i>16 - how to use the steam function</i> <i>17 - how to use the slow cook function</i> <i>17 - how to use the delay timer</i>
18	safety features
19	how to cook with frozen foods
19	cleaning and maintenance
20	troubleshooting
23	helpful tips
24	cooking time chart
28	recipes <i>28 - savory pressure cooker recipes</i> <i>48 - dessert recipes</i> <i>52 - slow cooker recipes</i>
59	warranty and return instructions

## PARTS IDENTIFICATION

1. Handle
2. Lid
3. Pressure Limiting Valve
4. Float Valve (external view)
5. Float Valve (internal view)
6. Inner Pot
7. Outer Pot
8. Main Body Handles
9. Upper Ring
10. Control Panel
11. Power Cord
12. Condensation Cup
13. Main Body
14. Heating Plate
15. Bottom Ring
16. Seal Ring for Float Valve
17. Filter
18. Rubber Seal Ring
19. Sensor
20. Stainless Steel Wire Rack
21. Tongs/Rack or Plate Lifter
22. Lid Rest (lid latches onto side handle)
23. Tab for Lid Rest
24. Lid Release Button

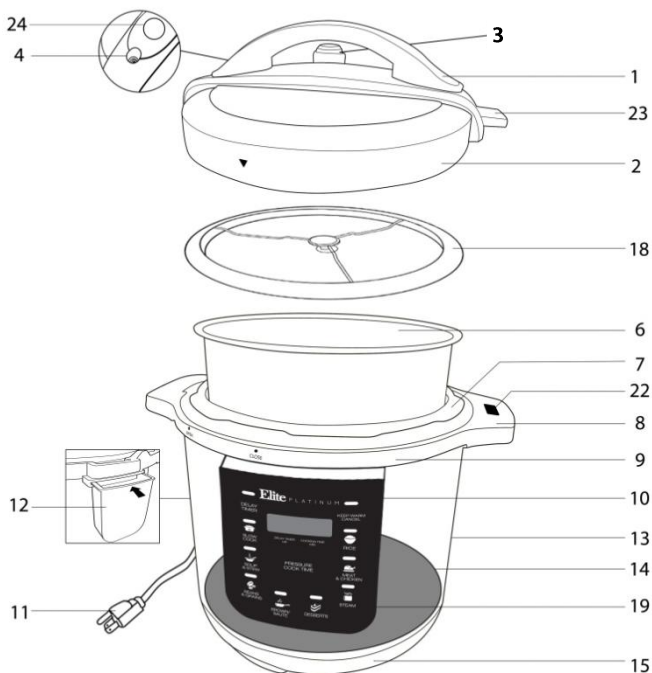

### UNDERSIDE OF LID

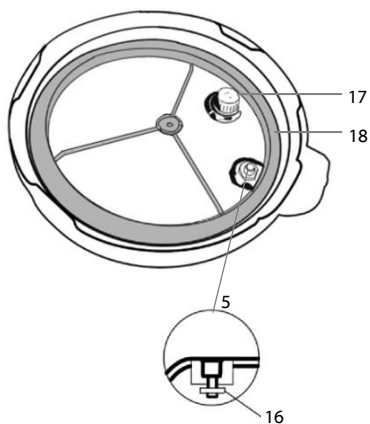

### ACCESSORIES

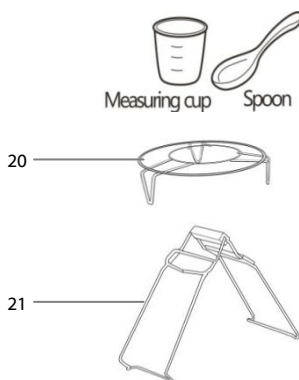

HOW TO USE THE CONTROL PANEL

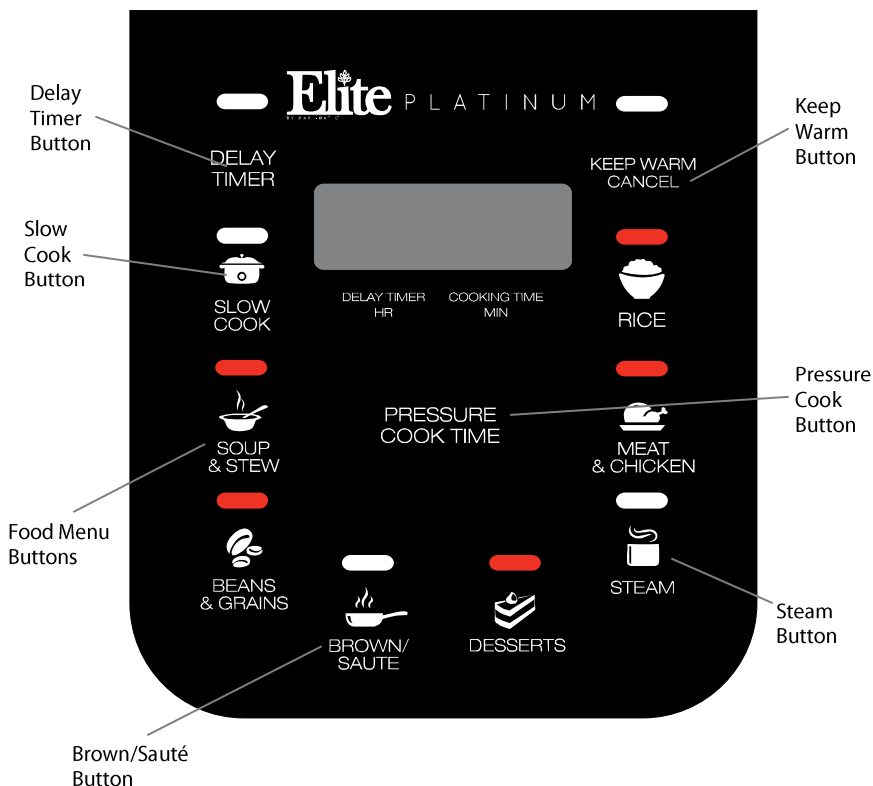

**FOOD MENU BUTTONS:** Use these buttons to select a Menu function, the pressure cooker will automatically begin the cooking cycle.

**PRESSURE COOK TIME BUTTON:** Use this button to set a custom Pressure Cook Time. First press a MENU button (see COOKING TIME RANGE chart on page 13), then press the PRESSURE COOK TIME button to set a custom cook time. Each press of this button increases cook time by 1 minute increments. Hold for rapid increase of time, there is no need to press any other button, the selected Menu function will begin cooking automatically.

**SLOW COOK BUTTON:** Use this button to program the Slow Cook function. Each press of the button increases Slow Cook time by 30 minutes.

**STEAM BUTTON:** Use this button to program the Steam function. Then use the PRESSURE COOK TIME button to program the cook time.

**DELAY TIMER BUTTON:** Use this button to program the pressure cooker to begin cooking at a later time. This button is used in combination with the Menu, Slow Cook, Steam or the Pressure Cook Time buttons.

**BROWN/SAUTÉ BUTTON:** Use this button to use the Brown/Sauté function. Then use the PRESSURE COOK TIME button program the Brown/Sauté time.

**KEEP WARM BUTTON:** Use this button to set the Pressure Cooker to Keep Warm. The Pressure Cooker will automatically set itself to Keep Warm after cooking. Also press this button to Cancel ANY function at ANY time.

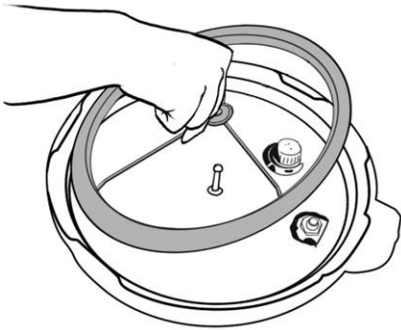

Figure 1

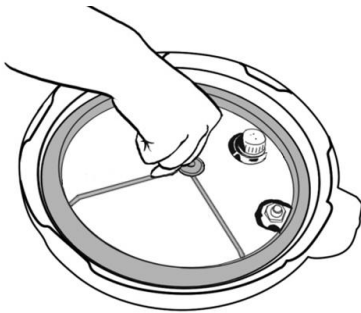

Figure 2

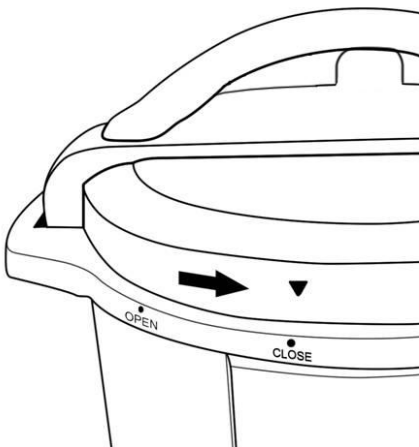

Figure 3

### **RUBBER SEAL RING ASSEMBLY**

Always ensure the Rubber Seal Ring (18) is securely fitted onto the metal Y-shaped ring in the interior of the Lid (2). Make sure the crease in the Rubber Seal Ring (18) meets with the outside of the Y-Ring all the way around. Then place the Y-Ring and Rubber Seal Ring (18) back into the Lid (2) making sure the hole in the center of the Y-Ring's cross-section is lined up with the metal pin in the center of the Lid (2). Press down firmly until the Y-Ring is secured onto the Lid (2) (Figures 1-2).

### **PRESSURE COOKER LID MARKINGS**

Please note the "OPEN" and "CLOSE" markings on the Upper Ring (9) of the pressure cooker body (13) and the "▽" on the rim of the Lid (2). To properly close and secure the pressure cooker Lid (2), always line up the "CLOSE" marking on the Upper Ring (9) and the "▽" on the rim of the Lid (2). (Figure 3)



## PARTS IDENTIFICATION (cont.)



Figure 4

### PRESSURE LIMITING VALVE WARNING

**WARNING:** Avoid serious injury. Always use tongs or a long kitchen tool to set the valve to EXHAUST (Figure 4).

**CAUTION HOT STEAM:** KEEP HANDS AND FACE AWAY FROM THE PRESSURE LIMITING VALVE WHEN ROTATING TO EXHAUST.

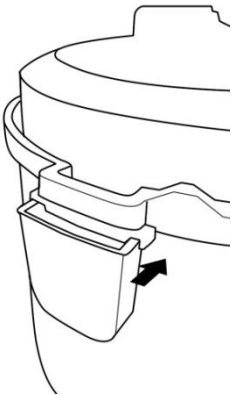

Figure 5

### CONDENSATION CUP ASSEMBLY

The Condensation Cup is the clear plastic piece that snaps into the back side of the pressure cooker as shown in Figure 5.

Place condensation cup in rear of the unit until it locks into place; it is part 12 in the diagram on page 5.

**FLOAT VALVE ASSEMBLY**

If there is steam escaping from the Lid and the Pressure Limiting Valve (3) on top of the Lid is in the Airtight position please see Troubleshooting on pages 20-22.

It is also important to ensure the Red Float Valve (4) is assembled correctly. Incorrect assembly may cause steam to escape from the sides or prevent pressure from building. The Red Float Valve (4) should be able to move up and down freely only stopping when the Seal Ring (16) meets the Lid (2). It is however normal for condensation to appear in the condensation collector. See illustration below for assembly.

**DIS-ASSEMBLY OF FLOAT VALVE (4)**

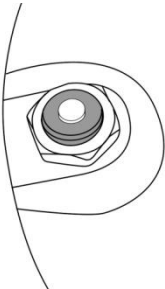

Hold Lid (2) upside down to locate the Float Valve (4). Ensure that there is something underneath the Lid (2) that can catch the Float Valve.

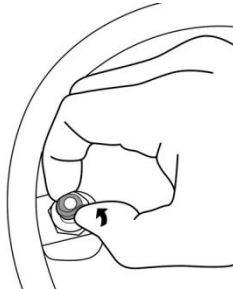

Grasp and pull off the Seal Ring for Float Valve (16).

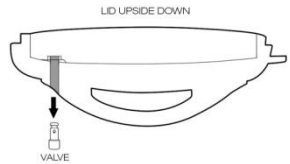

The Float Valve (5) will drop out from the Lid (2). Check and clean the hole, the Seal Ring (16) and the Float Valve (5).

**ASSEMBLY OF FLOAT VALVE (4)**

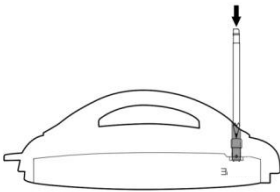

Insert fluted end of Float Valve (4) into the hole in the Lid (2) and use a pencil or other slim tool to hold in place.

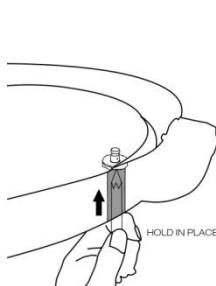

Flip the Lid (2) upside down while using the pencil to hold the Float Valve (4) in place.

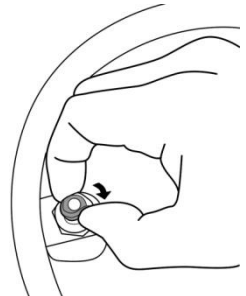

Place the Seal Ring (16) onto the fluted end of the Float Valve (4) so it sits in the groove. The Float Valve (4) should be able to move up and down freely only stopping when the Seal Ring (16) meets the Lid (2).

## ADDITIONAL SAFETY TIPS

- Always keep hands and face away from Pressure Release Device when releasing pressure.
- Use extreme caution when removing the lid after cooking. Always tilt the lid away from you, so any remaining steam is away from your face.
- Never attempt to open lid while cooking, or before the Red Float Valve (4) has dropped. Do not attempt to defeat this safety feature by forcing lid open.
- Do not cover or block the pressure valves.
- Do not touch the pot or lid except for the handle immediately after using.
- To avoid burns, allow food to cool before tasting. The temperature of the food gets considerably hotter than with conventional cooking.
- Ensure that the gasket is properly in place and is free of food particles or is not damaged in any way.
- **WARNING!** Do not release steam manually with recipes containing lots of liquid, such as soups and stews. Make sure the "KEEP WARM" indicator light is on and unplug the cooker. Allow to sit until the lid turns without any resistance.
- Do not fill unit over 2/3 full. When cooking foods that expand during cooking such as rice, legumes, beans, or dried vegetables, do not fill the unit over 1/2 full. Overfilling may cause a risk of clogging the pressure limiting valve and developing excess pressure. Failure to follow this procedure can result in injury to person(s) and/or damage to the unit. See "INSTRUCTIONS FOR USE" section in this manual.
- Be aware that certain foods, such as applesauce, cranberries, pearl barley, oatmeal or other cereals, split peas, noodles, macaroni, rhubarb, or spaghetti can foam, froth, and sputter, and clog the pressure release device (steam vent). These foods should not be cooked in a pressure cooker unless following a Maxi-Matic® approved pressure cooker recipe.
- This appliance cooks under pressure. Improper use may result in scalding injury. Make certain unit is properly closed before operating. See "INSTRUCTIONS FOR USE" section in this manual.
- Always check the pressure release devices for clogging before use.
- Do not use the pressure cooker without liquid; this could damage the pressure cooker severely.
- Do not use pressure cooker for storage purposes nor insert any utensils.
- This is NOT a Stovetop Pressure Cooker. Under NO circumstances should this Pressure Cooker or any of its parts or components be placed ON or NEAR a Stovetop, Range, or Open Flame. Doing so will cause serious damage to the Pressure Cooker and/or injury to person.

## BEFORE FIRST USE

1. Remove packaging materials such as cardboard, plastics or Styrofoam and discard appropriately.
2. Clean all the parts by wiping with a soft damp cloth or sponge and dry thoroughly.
3. Thoroughly clean the cooking pot in the dishwasher or with warm soapy water. Rinse, towel or air-dry, and place in the pressure cooker.

## BEFORE FIRST USE (cont.)

### LID ASSEMBLY:

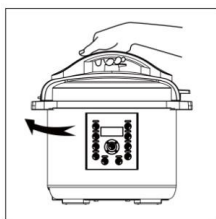

Figures 6 - 8

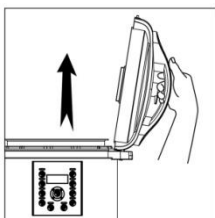
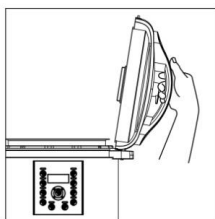
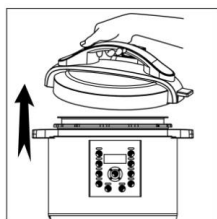

Figures 9 - 11

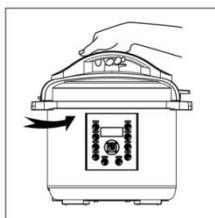
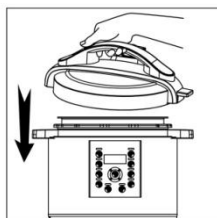

**How to open the lid:** Hold the handle (1) firmly while pushing down on the red lid release button (24), turn the lid (2) clockwise until it loosens and lift vertically (Figures 6-7); the lid (2) can stand on the Lid Rest (22) (Figure 8).

**Note:** For new units, the seal of the lid (2) may be

slightly stronger than normal and may be slightly difficult to unlock. Once the lid (2) has been opened and closed several times, it will loosen up.

**How to close the lid:** Observe the Rubber Seal Ring (18) inside the lid (2) and ensure that it is fitted onto the outer part of the Y-Ring all the way around. (Caution: If the rubber seal ring is damaged, do not use the pressure cooker. Contact Customer Service to repair or replace). To lock lid in place, remove any food residue from upper rim of cooking pot to ensure a proper seal. Take the Lid (2) off the Lid Rest (22) (Figure 10), hold the Handle (1) and close it downwards at the Opened Lid position (Figure 10). Turn counter-clockwise until you reach the Closed Lid position (Figure 11). (A clamping sound can be heard).

*Note: To ensure you are properly closing the lid (2), line up the OPEN and CLOSE markings on the Lid (2) and Main Body (13).*

### WATER TEST

For the first use, to ensure correct assembly of the Rubber Seal Ring (18), it is recommended to read the following instructions and fill the Inner Pot (6) with water to the 2/3 line and program to pressure cook for 30 minutes. Once completed, pour out the water. Rinse and towel dry the Inner Pot (6). The pressure cooker is now ready for use.

### LID SAFETY LOCK SYSTEM

*\*Note: This unit has a built-in safety feature that prevents all functions from activating if the Lid (2) is not properly locked/secured into place.*

*A cooking function cannot be selected if the Lid (2) is not properly locked/secured into place. The display will show "LID" and continuously beep until the Lid (2) is properly closed. You will not be able to select a cooking function.*

*This is to prevent the unit from cooking without the lid being properly secured. The BROWN/SAUTÉ function will still work as this function does not use the Lid (2).*

## INSTRUCTIONS FOR USE

### COOKING POT MARKINGS

Inside the removable cooking pot are two sets of markings. One side is marked "2/3 MAX PRESSURE COOK", which indicates the maximum fill line when cooking any food, other than rice in the pressure cooker. The other marking is MAX RICE CUP and is used when cooking rice. When pressure cooking rice, never fill the pressure cooker with water past the 4 cup marking.

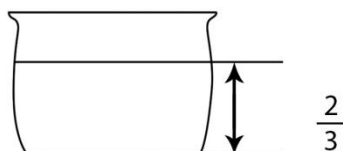

Figure 12

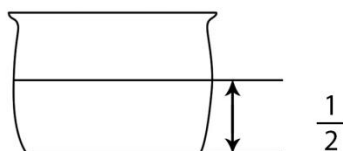

Figure 13

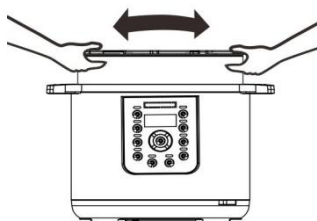

Figure 14

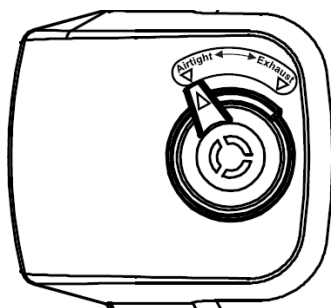

Figure 15

1. Open lid, remove cooking pot from pressure cooker and add food and liquids as the recipe directs.

**NOTE:** The total volume of food and liquid must not exceed 2/3 of the capacity of the cooking pot (Figure 12). For foods such as dried vegetables and beans, or rice and grains, the total volume must not exceed 1/2 the capacity (Figure 13). Overfilling may clog the pressure limit valve, which can cause excess pressure to develop. Always use at least 1/2 cup liquid when pressure cooking.

**WARNING:** To avoid a serious burn injury when cooking foods other than rice, never exceed the 2/3 MAX PRESSURE COOK mark of the combined volume of liquids and solids.

2. Be certain the inner receptacle, where the heating plate (14) is located, is clean and dry before inserting the Inner Pot (6) into the pressure cooker and adjust the pot left and right to ensure optimal contact between the Inner Pot and the heating plate (14) (Figure 14).
3. Close and "LOCK" the lid.
4. Adjust the Pressure Limiting Valve (3) to the "Airtight" position, and ensure that the Red Float Valve (4) sinks.
5. When adjusting the Pressure Limiting Valve (3) to either the "Airtight" or the "Exhaust" positions, line up the marking on the Pressure Limiting Valve (3) with the arrow on the Handle (1) as shown in Figure 15.
6. Plug the power cord into the pressure cooker and then into the wall outlet. The LED display will show 00 00.

## OPERATING INSTRUCTIONS

With the lid secured, unit on and the LED displayed, select the button for the desired cooking function by reading the following instructions.

There are eight MENU BUTTONS programmed for your pressure cooker. They are SLOW COOK, SOUP & STEW, BEANS/GRAINS, BROWN/SAUTÉ, DESSERTS, STEAM, MEAT & CHICKEN, and RICE. The default times are programmed for quick and easy cooking for small portions of food less than 3lbs. When cooking food that is more than 3lbs. use the Custom PRESSURE COOK TIME function. Each of the default times is programmed to detect the weight of food being cooked and how much liquid is inside the pot during the cooking cycle. The unit will automatically build up the pressure, cook the food and go to KEEP WARM when cooking is complete.

MENU BUTTON	DEFAULT COOKING TIME	COOKING TIME RANGE
RICE	12 MIN	N/A
SOUP & STEW	25 MIN	1-90 MIN
MEAT & CHICKEN	12 MIN	5-60 MIN
SLOW COOK	6 HOURS	0.5-9.5 HOURS
BEANS & GRAINS	40 MIN	10-90 MIN
BROWN/SAUTÉ	5 MIN	3-8 MIN
STEAM	5 MIN	3-25 MIN
DESSERTS	18 MIN	5-33 MIN

### AFTER SELECTING A MENU BUTTON (RICE, SOUP & STEW, MEAT & CHICKEN, SLOW COOK, BEANS & GRAINS, BROWN/SAUTÉ, STEAM, AND DESSERTS)

1. The Default Cook Time will display for the selected setting. For example, if RICE is selected, the display will show P12. **There is no need to press any other button.**
2. The RICE Indicator will blink five times and the unit will begin heating.
3. As the unit heats up and pressure builds, the Red Float Valve (4) will rise. The amount of liquid and other ingredients in the pressure cooker determines the length of time needed for full pressure to build - generally 5 to 40 minutes, depending on the recipe.
4. Using the same RICE example, while the unit is building up pressure the LED display will show a scrolling 00 12. The LED screen will not begin to countdown until the pressure has built up to capacity. Once it begins to pressure cook, the LED display will show a solid P:12 and begin countdown.
5. The raised Red Float Valve (4) indicates you are cooking under pressure. The lid is now locked and cannot be opened. **YOU SHOULD NEVER ATTEMPT TO OPEN THE LID WHILE PRESSURE COOKING.**

### AFTER SELECTING PRESSURE COOK TIME

1. The PRESSURE COOK TIME button is used in combination with the MENU buttons.
2. Using BEANS & GRAINS as an example, first press the BEANS & GRAINS button, then quickly press the PRESSURE COOK TIME button to increase in 1 minute increments.

## OPERATING INSTRUCTIONS (cont.)

Hold the button down for rapid increase of cooking time up to 90 minutes. The desired cook time will show on the display. For example, if 70 minutes of cook time is selected, the display will show P70. **There is no need to press any other button.**

- **TIP:** *If you wait too long to set the PRESSURE COOK TIME, the cooker will begin operation and you will no longer be able to adjust the time. Cancel the cooking process to start over.*
3. The indicator light will blink five times and the unit will begin heating.
  4. Follow steps 3-5 from page 13.
    - **TIP:** *For setting a shorter time, start with the FISH & VEGETABLES button and then use the PRESSURE COOK TIME button to reach a cook time minimum of 3-minutes.*

### AUTO-KEEP WARM FEATURE

When cooking has completed, the pressure cooker will beep 3-times and automatically go to KEEP WARM. The KEEP WARM indicator light will illuminate and the display will show bb.

- **NOTE:** *The KEEP WARM setting should not be used for more than 4 hours. The quality and texture of food will begin to change after 1 hour on KEEP WARM. A bit of condensation in the upper ring during KEEP WARM is normal. To set the cooker to KEEP WARM, press the KEEP WARM/CANCEL button until the display shows bb.*

### TO RESET OR CANCEL

User can reset or cancel any function at anytime by pressing the KEEP WARM/CANCEL button until the display shows 00 00.

### REMOVING LID AFTER PRESSURE COOKING

When the pressure cooking cycle has completed, the unit will automatically switch to KEEP WARM. At this point you may release pressure in one of two ways - Natural Pressure Release or Quick Pressure Release.

1. Natural Release: Following pressure cooking, allow the unit to remain on KEEP WARM. The pressure will begin to drop - time for pressure to drop depends on the amount of liquid in the cooker and the length of time that pressure was maintained. Natural Release can take from 15 to 30 minutes. During this time cooking continues so it is recommended for certain cuts of meats, soups, rice, and some desserts. When pressure has fully released, the Red Float Valve (4) will drop and the lid will unlock to open. As a safety feature, the lid will not open unless all pressure is released. **Do not force the lid open.** If the lid feels tight, please allow additional time for pressure to fully release before attempting to open the lid.
2. Quick Release (recommended for foods that should be Medium or Medium-Rare): Following pressure cooking the cooker will beep 3 times and go to KEEP WARM. Press the KEEP WARM/CANCEL button and the display will show 00 00. Using an oven mitt or long utensil, carefully turn the Pressure Limiting Valve (3) to the "Exhaust" position to release pressure until the Red Float Valve (4) sinks (Figure 16).
  - **CAUTION HOT STEAM – RISK OF SCALDING:** USE TONGS OR LONG UTENSIL TO TURN THE VALVE. KEEP HANDS AND FACE AWAY FROM PRESSURE LIMITING VALVE (3)

## OPERATING INSTRUCTIONS (cont.)



Figure 16

**WHILE IN THE EXHAUST POSITION. FAILURE TO COMPLY MAY CAUSE SERIOUS INJURY (Figures 17-18). DO NOT RELEASE PRESSURE UNDER HANGING CABINETS WHICH CAN BE DAMAGED BY STEAM.**

- Always use an oven mitt to reduce risk of injury. Failure to comply may cause serious injury.
- foods with a high volume of liquid (Stews, soups, porridges, etc.).

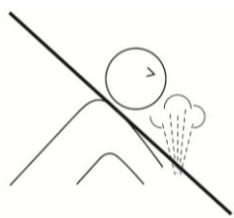

Figures 17 - 18

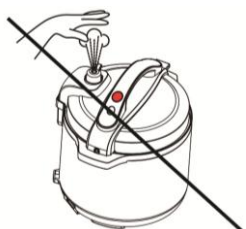

Steam will immediately begin releasing from the Pressure Limiting Valve (3). When pressure is fully released, the Red Float Valve (4) will sink and the lid will unlock to open. As a safety feature, the lid will not open unless all pressure is released. **Do not force the lid open.**

*If the lid feels tight, please allow additional time for pressure to fully release before attempting to open the lid. If there is any resistance in opening the lid it indicates that your Pressure Cooker is still under pressure and can cause injury if forced open. When the Red Float Valve is completely down, turn lid clockwise and lift to remove. Always open the lid away from you to avoid skin contact with any remaining heat or steam.*

### ADDING SEASONING OR INGREDIENTS AFTER PRESSURE COOKING:

1. Follow instructions under **REMOVING LID AFTER PRESSURE COOKING** on page 14.
2. Allow Inner Pot (6) to cool so it can be safely removed from the pressure cooker using heat-resistant mitts or gloves.
3. Carefully add desired seasoning or ingredients to Inner Pot (6).
4. Using heat-resistant mitts or gloves place Inner Pot (6) back into main body of cooker (13).
5. Depending on contents, wait 10-30 minutes before placing Lid (2) onto unit. Lid (2) should turn smoothly, if there is resistance, remove lid and wait another 10 minutes. Before re-programming pressure cooker, ensure Lid (2) is turned and locked securely into place by following instructions on pages 7 and 11.

### PREPARING WHITE RICE

When measuring rice, **ONLY USE THE RICE MEASURE CUP PROVIDED; DO NOT USE A STANDARD MEASURING CUP.** Use the Rice Measure Cup, along with the pot markings to make perfect rice every time. For example, when making 4 cups of rice, use 4 rice cup measures of rice and fill with water to the "4" mark. As a general rule, when cooking 2 cups (or less) of uncooked rice, use 1 tablespoon of butter or oil. For measurements greater than 2 cups, use 2 tablespoons of butter or oil. This will prevent foaming during the cooking process.

- *When cooking rice, the maximum amount of rice allowed for this 4 quart pressure cooker is 4 cups of uncooked rice.*



## OPERATING INSTRUCTIONS (cont.)

- *Normally one cup of rice requires one cup of water. This may vary according to taste.*
- *For best results rinse measured rice until the water becomes relatively clear.*

### HOW TO BROWN/SAUTÉ

This setting allows cooking over high heat, without the lid, before pressure cooking. Before Pressure Cooking, most recipes will benefit from the golden color, richer flavors and moist results gained from Browning/Sautéing.

To Brown or Sauté your meats or vegetables prior to pressure cooking:

1. Remove Lid (2) from unit. **BROWN function will not work unless Lid (2) is removed.**
2. Press the BROWN/SAUTÉ button. Press the PRESSURE COOK TIME button to increase the time. **There is no need to press any other button.**
3. Add oil or butter as directed in your recipe and then place food into the Inner Pot (6).
4. Stir or turn food as needed until desired color and consistency is reached.
5. Press the KEEP WARM/CANCEL button if you want to cancel the BROWN/SAUTÉ function before the timer finishes counting down.
  - *Allow the unit to rest 2-3 minutes after cancelling the BROWN/SAUTÉ function before beginning to pressure cook. If the unit will not begin pressure cooking, allow it to cool for a longer period after BROWNING/SAUTÉING before selecting another function.*

### HOW TO USE THE STEAM FUNCTION:

1. Place wire rack (20) into Inner Pot. A stainless steel wire rack or trivet no larger than 7.8" in diameter is recommended for use with this pressure cooker.
2. Place heat resistant dish or container on top of wire rack (20).
3. Add water to a level just below the top of the wire rack (20).
4. Place food in heat resistant container on the wire rack (20). Do not fill pot more than 2/3 full with food. If steaming rice, put rice in an 8 inch or smaller bowl and place on wire rack (20).
5. Secure the Lid onto the unit, turn it Counter-clockwise to lock it in place properly.
  - The STEAM function can be used w/ pressure (turn Pressure Limiting Valve (3) to AIRTIGHT), or w/o pressure (turn Pressure Limiting Valve (3) to EXHAUST).
6. Press the STEAM button, the display will show P5 as the default cook time.
7. Set the desired cooking time by pressing the PRESSURE COOK TIME button once for each additional minute or hold for rapid increase. The longest steam time allowed is 25 minutes.
8. Once desired STEAM time is displayed, **there is no need to press any other button.**
9. The Indicator Light will blink five times and then illuminate solid when it begins operation.
10. When proper pressure is achieved, the display will show the desired cook time and begin counting down.
11. When cooking has completed, the pressure cooker will beep 3-times and automatically go to KEEP WARM. The display will show bb during KEEP WARM.
12. Press the CANCEL button to end operation.

## OPERATING INSTRUCTIONS (cont.)

- **CAUTION!** Never put your face or hands directly over the cooker when removing Lid (2), escaping steam can cause serious burn injury.

### HOW TO USE THE SLOW COOK FUNCTION:

1. Prepare desired food and place into Inner Pot (6).
  2. Secure the Lid (2) onto the unit, turn it clockwise to lock into place.
    - The SLOW COOK function is used without pressure (turn **Pressure Limiting Valve** (3) to EXHAUST).
- Press the SLOW COOK button once and the display will show the default SLOW COOK time of **06:00**. **Quickly** continue to press the SLOW COOK button to increase cook time in increments of 30 minutes.
5. Hold the SLOW COOK button down for rapid increase of cooking time.
    - **NOTE:** The longest SLOW COOK time allowed is 9.5 hours.
    - **TIP:** If you cannot adjust the SLOW COOK time, it is because too much time has passed since you first pressed the SLOW COOK BUTTON. Cancel the cooking process. Then press the SLOW COOK button continually until you've reached the desired cook time.
  6. **There is no need to press any other button.**
  7. The SLOW COOK indicator will blink five times and then illuminate solid once it begins operation.
    - The unit may take between 5~20 minutes to reach temperature before beginning count down.
  8. When cooking is complete, the cooker will beep 3-times and automatically go to KEEP WARM. The display will show **bb** during KEEP WARM.
  9. The KEEP WARM indicator light will illuminate. Press CANCEL to end the operation.
    - **CAUTION!** Never put your face or hands directly over the cooker when removing Lid (2), escaping steam can cause serious burn injury.

### HOW TO USE THE DELAY TIMER

If you wish to Program your pressure cooker to automatically cook prepared food at a later time, you can program the pressure cooker to delay cooking by up to 24-hours.

**CAUTION:** It is not recommended to use the Delay Timer function to cook foods that may spoil. Leaving raw foods inside the pressure cooker for long periods of time prior to cooking may result in the food spoiling. Cook food that can be left out such as rice, beans, grains or other foods that will not spoil.

This setting is used in combination with the MENU functions and the PRESSURE COOK TIME function.

1. Prepare desired food and place into cooking pot.
2. Secure the Lid (2) onto the unit, turn it Counter-clockwise to lock it in place.
3. Make sure the Pressure Limiting Valve (3) is set to the "Airtight" position.
4. Plug the power cord into a 120V power outlet.
5. The LED screen will display **00 00**.
6. Press the DELAY TIMER button. The LED screen will show **0:30** which is equal to 30

## OPERATING INSTRUCTIONS (cont.)

minutes of delay time. Press it once for each additional 0.5-hour or hold for rapid increase. The maximum Delay period is 24-hours in half-hour increments. Pressing the delay timer button again after reaching the 24-hour setting will automatically reset the delay timer to zero. (The time that displays on the LED screen shows how long the user wants the unit to wait before the cooking process begins.)

7. EX: If you wish to program the pressure cooker to automatically turn on in 3-hours, press the DELAY TIMER button until the LED screen displays 3:00).
8. After programming your Delay time, select the desired function.

### MENU SELECT BUTTONS:

- Select one of the 8 MENU BUTTONS.
- Follow the instructions under "AFTER SELECTING A MENU BUTTON."

### PRESSURE COOK TIME:

- Follow the instructions under "AFTER SELECTING PRESSURE COOK TIME."
9. Once the pressure cooker completes its countdown, the unit will begin operation of the cooking sequence for the chosen selection.
  10. Follow instructions under "HOW TO REMOVE LID AFTER PRESSURE COOKING" to finish the cooking process.

## SAFETY FEATURES

There are nine safety devices installed in the pressure cooker to assure its reliability.

1. **Open-and-Close Lid Safety Device**  
The lid cannot be opened if the appliance is filled with pressure.
2. **Pressure Control Device**  
The correct pressure level is automatically maintained during cooking cycle.
3. **Pressure Limiting Valve (3)**  
The pressure limiting valve will release air automatically when the pressure inside exceeds the preset temperature.  
*NOTE: Overfilling the pressure cooker (see Instructions for Use) may clog the pressure limiting valve, which can cause excess pressure to develop.*
4. **Anti-Block Cover**  
Prevents food material from blocking the pressure limiting valve (3).
5. **Pressure Relief Device**  
When the cooker reaches the maximum allowable pressure and temperature, the cooking pot will move down until the lid separates from the sealing ring, releasing air pressure.
6. **Thermostat**  
The power will auto-shut-off when the cooking pot temperature reaches the preset value, or the pressure cooker is heating without enough liquid inside.
7. **Thermal Fuse**  
The circuit will be opened when the pressure cooker reaches the maximum temperature.
8. **Lid Safety Switch**  
The pressure cooker will not function if lid is not properly secured into place.
9. **Lid Safety Button**  
The lid cannot be opened if the button is not pressed and held.

## COOKING FROZEN FOODS

Cooking frozen food inside a pressure cooker is quick and easy but has certain restrictions. Only cook individual cuts of frozen meats that are up to 1 inch thick, the cooking time does not need to be altered. Pressure will not be achieved until the internal temperature has reached a preset level. If the recipe states the meat should be cooked for 10 minutes after pressure has been achieved, it will still be the same, but it will take longer to reach the required pressure point.

It is not recommended to pressure cook larger cuts of frozen meats such as a whole roast, a block of frozen ground meat or a whole chicken. Larger cuts will require increased cooking times of up to one third more, and the results may not be the same when compared to meats that were thawed (or at least partially thawed) and browned before cooking.

## CLEANING AND MAINTENANCE

1. Always make sure the Pressure Cooker is unplugged, depressurized and completely cooled down before dismantling.
2. Use a non-abrasive sponge or damp wash cloth to clean the outer body (13). NEVER immerse the outer body (13) in any liquids or pour liquid into it.
3. Remove the Condensation Cup (12) and rinse it thoroughly and let dry. Clean the Inner Main Body (13) and Upper Ring (9) with a damp sponge or wash cloth.
4. Remove the pressure limiting valve (3) by gripping and firmly pulling upwards. Rinse with warm water and dry.
5. Clean the Lid (2) with warm soapy water, including the Rubber Seal Ring (18), Filter (17), Vent, Float Valve (4) and let dry thoroughly.
6. On the underside of the lid below the pressure limiting valve (3), is a small metal filter (17) which can be easily removed to clean (Figure 19).
7. Let parts dry completely before reassembling.
8. Wash the Inner Pot (6) and Wire Rack (20) with a non-abrasive sponge and allow to air dry or use a towel. It is not recommended to use any type of scouring pad that can scratch the non-stick surface of the Inner Pot (6).
9. Store the inner pot inside of the Pressure Cooker. Store Pressure Cooker in a cool, dry location.
10. Do not store pressure cooker with lid on tightly. This saves on gasket wear and tear.
11. **NOTE:** Any other servicing should be performed by an authorized service representative or from the original manufacturer or distributor.

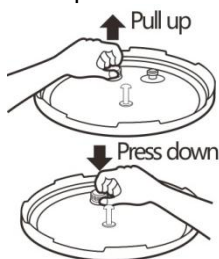

Figure 19

### How to Clean the Filter:

To clean the filter (17), remove it by pulling vertically. To re-attach, simply line up the filter (17) and press down to secure the filter (Figure 19).

## TROUBLESHOOTING

PROBLEM	SOLUTION
1. Is the Pressure Limiting Valve (3) on the lid (2) supposed to be loose?	Yes even though it will have a loose fit it is safely secured. It will turn 360 degrees. When pressure has built up, and the Valve is set to "Airtight" properly, it will resemble a bobble head.
2. When I choose a Menu Button (ex: SOUP & STEW), nothing happens? What's wrong?	<p>Nothing is wrong. Make sure the pressure limiting valve (3) is set to Airtight and the Lid (2) is locked securely. Once you have selected the Menu Button, simply leave the unit alone and it will start to heat and build up pressure.</p> <p>Once the unit has built up enough pressure, the display will change to a countdown timer that displays your desired cooking time of the Menu Button you selected. This is the time the unit will start cooking the food. Pressurizing can take anywhere from 5 minutes up to 40 minutes depending on the quantity of food you are cooking.</p>
3. After I set the pressure cooker it will begin to heat up, but in about 5-minutes the unit beeps 3 times and goes to Keep Warm and my food did not cook completely. What is happening?	The unit is detecting that not enough liquid has been added to your recipe. The pressure cooker has an automatic over-heat protection sensor that will automatically set itself to OFF or Keep Warm when it detects that not enough liquid is present so that it does not over-heat. Make sure all pressure is released, open the lid and add in increments of 1/2 cups of liquid until the unit will properly build up pressure and cook.
	The unit is detecting that there is a leak in the pressure and that it is not sealed properly. Firmly push down on the lid to help the seal form or release any built up pressure and safely remove the lid to check the unit thoroughly. Make sure the rubber gasket ring is in place, the lid is securely locked, and that the Valve on top of the lid is set to the "Airtight" position. Reset the unit by unplugging it. Wait 10-seconds and plug it back in. Program the unit again.
	Both of the above solutions will cause some liquid to have evaporated and it is recommended to add back in any liquid that has evaporated otherwise you will keep encountering the same issue.
4. Steam is being released around the rim of the lid during the pressurizing sequence. How do I fix this?	Please note that steam escaping from the Valve (3) or around the lid is normal for the first 5 minutes or so during the Pressurizing process. If it continues beyond 10 minutes or steam is still releasing when the timer has begun counting down it may mean that the Rubber Seal Ring (18) did not form a tight seal when the Lid (2) was locked. This can happen to brand new units. Try pressing down firmly on the Lid (2). This should allow the Rubber Seal Ring (18) to seal and stop any more steam from releasing.
	If this does not fix the issue, press the KEEP WARM/CANCEL button and follow the instructions to release all pressure before removing the lid to check the Red Float Valve (4) or the Rubber Seal Ring (18). See page 7 on how to install the Rubber Seal Ring (18). Rub a wet cloth along it to make sure it is clean of debris and it is smooth. Note that the Red Float Valve (4) is properly assembled and you are able to pull it up and down with ease by grasping the Float Valve Seal Ring (16). Reposition and secure the lid. Start the cooking process again.

PROBLEM	SOLUTION
5. Steam is being released from the Pressure Limiting Valve (3) during the pressurizing sequence. How do I fix this?	This may happen during the initial start-up of the Pressurizing Sequence and is normal. If it continues for more than 10 minutes, the Valve (3) may not be positioned properly. Simply use tongs or similar utensil and oven mitt and carefully adjust the valve by gently tapping it side to side until it seals properly. If the steam continues to release, you may need to press the KEEP WARM/CANCEL button. Follow the instructions to release all pressure before opening the lid to remove the Pressure Limiting Valve and check the thin wire spring on the underside of it. Make sure it is not bent or loose. If steam still continues to escape, the Valve may be faulty and replacement or repair may be necessary. Please contact customer service at (800) 365-6133 ext. 120/107/105.
6. Steam is being released from the Red Float Valve (4) area during the pressurizing sequence. How do I fix this?	This may happen during the initial start-up of the Pressurizing Sequence and is normal. If it continues for more than 10 minutes, simply use tongs or similar utensil and oven mitt to carefully adjust it so it is seated properly. This will help settle the lid and all the valves properly. The pressure will quickly push up on the Float Valve and seal properly to finish the pressurizing sequence.
7. My food is finished cooking and all the pressure is released, but I cannot unlock and open my lid. What is stuck?	Make sure all the pressure and steam has been completely released. Make sure the Red Float Valve (4) is no longer in the up position. It may be stuck in the UP position, simply tap the lid gently to make it go back down. Then turn the lid clockwise to unlock the lid. If it is still stuck, unplugging the unit may help.
8. What is the clear plastic part that came with my pressure cooker?	It is the Condensation Cup: Refer to part (12) on pages 5 and 8 to attach the condensation cup to the back of the pressure cooker.
9. I've programmed the pressure cooker to cook but it's just sitting there and nothing appears to be happening.	The unit is still building pressure. This can take between 5-40 minutes depending on the quantity of food.
10. The unit is DEAD or has NO POWER.	The fuse in the unit has shorted out. This happens if the unit is cooked without enough liquid in the inner pot or if there is too much electrical current going to the cooker. Please contact customer service at (800) 365-6133 ext. 120/107/105 for a replacement fuse.
11. The LED display shows E4 error.	Unplug the power cord from the wall outlet. Wait approximately 15 minutes. Plug the power cord back into the wall outlet. Press "CANCEL" button on the pressure cooker. Select cooking process to begin cooking. If problem persists, contact customer service at (800) 365-6133 ext. 120/107/105 for a replacement thermofuse.
12. My food is burned at the bottom of the inner pot.	There is not enough liquid in the inner pot. Add more liquid to your inner pot contents.

<b>PROBLEM</b>	<b>POSSIBLE REASON</b>	<b>SOLUTION</b>
13. I'm having trouble closing the lid.	Sealing ring improperly installed.	Re-position the sealing ring.
	Float valve in the UP position.	Gently push the Float valve down.
14. I'm having trouble opening the lid.	Pressure has not been fully released.	Gently turn the Pressure limiting valve to EXHAUST to release remaining pressure.
	Float valve in the UP position.	Gently push the Float valve down.
15. A lot of steam keeps shooting out from the valve during cooking.	The valve is in EXHAUST position.	Move the Pressure limiting valve to AIRTIGHT position.
16. Display shows LID and keeps beeping.	Lid is not properly closed.	Fully turn Lid counter-clockwise to close in order to use pressure cooking functions.
17. Unit won't let me select a cooking function.	Lid is not properly closed.	Fully turn Lid counter-clockwise to close in order to use pressure cooking functions.
		Fully remove Lid from body in order to use BROWN/SAUTE function.
		Use glass lid for STEAM and SLOW COOK functions.
18. Display shows E3.	Overheating is detected.	Press CANCEL to stop cooking and check if food at the bottom of the inner pot is burnt.
19. Display is blank after plugging in power cord.	Bad power connection or no power.	Check the power cord from the pressure cooker to the wall outlet to ensure a good connection.
	Electrical fuse is blown.	Contact customer service at <a href="mailto:info@maxi-matic.com">info@maxi-matic.com</a> for a replacement fuse.
20. Rice only partially cooked or is too hard.	Didn't use enough water.	Adjust rice to water ratio according to recipe.
	Lid opened too early.	After cooking cycle is complete, leave the lid on for an extra 5 minutes.
21. Rice is mushy or watery.	Used too much water.	Adjust rice to water ratio according to recipe.

## HELPFUL TIPS

- Read this manual thoroughly and follow all instructions.
- Be familiar with the recipe and have all ingredients prepped before you begin.
- Be sure the lid is secured and locked properly before beginning.
- You may wish to brown some meats before cooking with other ingredients. To do so, follow instructions on page 15.
- Cut foods into equal-sized pieces to promote even cooking. In recipes that call for multiple ingredients, cut those that cook more quickly into larger pieces and those that cook more slowly into smaller pieces.
- Many different cooking liquids can be used in a pressure cooker: wine, beer, bouillon, fruit juices, water, broth and more.
- After becoming familiar with your pressure cooker, you can readily adapt conventional recipes to be used with a pressure cooker. In general, cut cooking times by two thirds. The amount of liquid used may also have to be reduced because there is very little evaporation in the pressure cooker. Reduce the required liquid so there is only about 1/2 cup more than desired in the finished product. Remember, however, there must always be some liquid in the pressure cooker to produce the necessary steam. Try using this rule; 1 cup of liquid for the first 15 minutes of pressure cooking then 1/3 cup of liquid for each subsequent 15 minutes. This can still vary, so if your unit will not build pressure you will have to add more liquid until it is able to build pressure. (See #3 in Troubleshooting on page 20).
- Since flavors are more intense, reduce the amounts of herbs and seasonings when adapting from conventional recipes. Fresh herbs are better for pressure cooking than dried.
- In general, pressure cookers cook foods in about 1/3 the time of conventional cooking methods.
- Increase cooking times by about 10% when cooking in high altitudes of over 3,500 feet.
- If you wish to cook food in less time than the pre-programmed amount, observe the timer and press CANCEL when desired cooking time has elapsed.
- Always check to make sure your gasket and float valve are clean, unobstructed and in good working order.
- When cooking under pressure, never fill above the fill line of the inner pot markings.
- If you are making soup and you are at the fill line, do not release pressure manually because hot liquid could spray out.
- Never attempt to open lid while under pressure and while Red Float Valve (4) is still up!!! Always open pressure cooker with the lid facing away from you.
- When manually releasing pressure, evaporation of some liquid may occur (i.e. when making rice or risotto). This is normal, but caution must be used to prevent injury.
- When cooking soups or stews with hearty ingredients such as potatoes or meat, as much as 5 or 6 cups of liquid must be used to prevent ingredients from over-cooking or burning.
- Never exceed the Maximum Fill Amount of the pressure cooker.
- Make sure lid is on firmly and tightly and moved as far counterclockwise as it will go to allow proper locking.
- Hot foods/liquids will come to pressure more quickly than cold foods/liquids.
- When pressure cooking is completed, follow recipe instructions for Quick or Natural Release.
- More nutrients are preserved during pressure cooking than with traditional cooking methods, as less liquid is used and thus fewer nutrients are lost to evaporation.
- Remember that it will take approximately 5 to 40 minutes (depending on the recipe) for pressure to build and pressure cooking to begin.



## COOKING TIME CHART

Please note that the information below is for your reference only and can be adjusted according to the user's preference.

### MEAT/POULTRY

- Always cook meat or poultry with at least 1-3 cups of liquid. If the cooking time exceeds 15 minutes, use 2 cups of liquid. If weight of meat or poultry is 3 lbs, use 3 cups of liquid. Preserved or salted meats should be immersed in water.
- Cooking times for meat and poultry may vary according to the quality and quantity of meat or poultry being cooked.
- Unless indicated. The cooking times given below are for 3 pounds of meat or poultry unless noted otherwise. Additionally, the denser the cut, the longer the cooking time should be.

Type of Meat	Approx. Cooking Minutes	Pressure Release
Beef/Veal, roast or brisket	38-42	Quick Release
Beef Meatloaf, 2 lbs.	13-18 or use the Meat Button	Quick Release
Beef, meatballs, 1-2 lbs.	7-12 or use the Meat Button	Natural Release
Beef, Corned	55-65	Natural Release
Pork, roast	43-47	Natural Release
Pork, ribs, 2 lbs.	18 or use the Meat Button	Quick Release
Pork, ham shank	25-28	Natural Release
Leg of Lamb	42-45	Natural Release
Chicken, whole, 2-3 lbs.	15-18 or use the Meat Button	Quick Release
Chicken, pieces, 2-3 lbs.	12-15 or use the Meat Button	Quick Release
Cornish Hens, two	12-15 or use the Meat Button	Quick Release
Meat/Poultry soup/stock	15-20 or use the Meat Button	Quick Release

### SEAFOOD

- Cooking times may vary according to the type of seafood being cooked.
- Cook seafood on a cooking rack with a trivet on the bottom of the pot (if available), and add at least 3/4 cup of liquid. Lightly grease cooking rack with vegetable oil when cooking fish.

Type of Seafood	Approx. Cooking Minutes	Pressure Release
Clams	3-5	Quick Release
Crabs	3-5	Quick Release
Lobster, 1 1/2 - 2 lbs.	3-5	Natural Release
Mussels	3-5	Quick Release
Shrimp	2-3	Quick Release
Fish, whole, gutted	7-8	Quick Release
Fish, Soup or Stock	7-8	Quick Release

## COOKING TIME CHART

- Always cook with at least 1-2 cups of liquid.
- Add 1-2 additional minutes to cooking time when preparing frozen vegetables.
- Use the quick-release release method at the end of cooking cycle to avoid over-cooking.

Type of Vegetable	Approx. Cooking Minutes	Pressure Release
Asparagus, thick whole	2-5	Quick Release
Asparagus, thin whole	1-2	Quick Release
Beans, fava, shelled	5	Quick Release
Beans, green, whole 1.5 lbs	4-5	Quick Release
Beans, lima, shelled	3	Quick Release
Beets, small, whole	2-3	Quick Release
Beets, large whole	23	Quick Release
Beets, 1-inch slices	5	Quick Release
Broccoli, flowerets	3	Quick Release
Brussel sprouts, whole	5	Quick Release
Carrots, 1-inch chunks	5	Quick Release
Carrots, 1/4-inch slices	1-2	Quick Release
Cauliflower, flowerets	3-5	Quick Release
Corn on-the-cob (4-6)	4	Quick Release
Escarole, coarsely chopped	2-3	Quick Release
Kale, coarsely chopped	2-3	Quick Release
Okra, small pods	3-5	Quick Release
Onions, whole	3	Quick Release
Potatoes, 1 1/2-inch chunks	7	Quick Release
Potatoes, new, small whole	6	Quick Release
Potatoes, sweet and yams, whole, medium	10-12	Quick Release
Potatoes, sweet and yams, 2" chunks	7-8	Quick Release
Spinach, fresh, coarsely chopped	3	Quick Release
Squash, acorn, halved	8	Quick Release
Squash, butternut, 1-inch chunks	5	Quick Release
Squash, summer, zucchini or yellow, 1/2-inch slices	6	Quick Release
Turnips, small quartered	4	Quick Release
Turnips, 1 1/2 inch chunks	4	Quick Release

**\*Split peas, applesauce, cranberries and rhubarb can foam, froth, and spatter, and can clog the pressure release device (steam vent). These foods should not be cooked in a pressure cooker.**

## COOKING TIME CHART

### DRIED BEANS AND OTHER LEGUMES

- Before cooking dried beans, pick over and discard any broken or shriveled beans or bits of dirt and debris. Rinse beans and drain.
- Beans may be soaked overnight, but the pressure cooker allows you to cook beans without presoaking.
- Onions, garlic, celery, springs of fresh herbs or a bay leaf may be added for additional flavoring. Do not salt before cooking as salt inhibits cooking.
- Never cook more than 2 cups of beans per batch (2 cups of beans + 8 cups of water + seasonings + onion, garlic, herbs to taste + 4 tsp oil).
- Add 2 tsp oil per cup of beans to prevent foaming.
- After cooking beans, clean lid, gasket, pressure limiting valve, and float valve carefully.
- Use natural pressure release when cooking beans.
- Cooking times may vary according to the quality of the beans or other legumes (this is partially dependent on the age of the dried beans, something you have no control over). If still hard after recommended cooking times, continue cooking uncovered. Add additional water, if necessary.

Type of Legume	Approx. Cooking Minutes (soaked overnight)	Approx. Cooking Minutes (unsoaked)	Pressure Release
Azuki	7-8	10-15	Natural Release
Black Beans	20-25	28-32	Natural Release
Black Eyed Peas	11-12	15	Natural Release
Chick Peas (garbanzo)	35-40	50-60	Natural Release
Gandules (pigeon peas)	8-10	11-13	Natural Release
Great Northern	25-30	30-35	Natural Release
Kidney Beans, Red	20	25-30	Natural Release
Lentils, green	N/A	10-12	Natural Release
Lentils, soup	N/A	8-10	Natural Release
Lentils, red	N/A	10-15	Natural Release
Lima Beans	7-8	9-12	Natural Release
Cannellini	18-22	33-38	Natural Release
Pinto	20-24	30-35	Natural Release
Navy beans	22-25	30-35	Natural Release
Soybeans	26-33	33-40	Natural Release

## COOKING TIME CHART

### RICE & GRAINS

Before cooking, soak certain grains, such as wheat berries and pearl barley in four times their volume of lukewarm water for at least four (4) hours or overnight if required. Do not soak rice. Do not add salt to water, since it may toughen the grains and inhibit hydration. Rice and grains are best slightly undercooked if they are to be added to soups or casseroles. Oil or butter must be added to prevent foaming.

Type of Grain	Approx. Cooking Minutes	Pressure Release
Kamut	30	Natural Release
Arborio	Saute rice in butter/oil until opaque. Pressure cook 6 minutes	Natural Release
Quinoa (1.5 cups quinoa + 2.25 cups liquid/water)	3	Natural Release
Rice, brown – 1 1/2 cups	Press RICE button	Natural Release
Rice, wild – 3 cups	Press RICE button	Natural Release
Wheat, berries – 3 cups	30	Natural Release
Amaranth (1 cup amaranth + 2 cups liquid/water)	7	Natural Release

*\* Pearl barley, oatmeal or other cereals can foam, froth, and sputter, and can clog the pressure release device (steam vent). These foods should not be cooked in a pressure cooker.*

*\*Cups referenced are with the included "rice measuring cup."*

### White Rice

Use this method for cooking long-grain or basmati rice. The texture will be more moist and slightly stickier than stovetop rice, more like rice from a rice cooker or Asian restaurants. The butter or oil are to prevent foaming. Salt is optional to taste (you may wish to omit salt completely if using a purchased broth).

White rice is cooked by pressing the RICE button and using Natural Release. See instructions on page 15 for directions to cook white rice.

Recipes on this page are courtesy of Joelle Hunter.

All listed recipes can be adjusted to double or triple the quantity.

### MACARONI N' CHEESE

SERVES 3

#### **Ingredients**

1 Tbsp butter	1 pound elbow noodles (or your favorite small pasta)
1 shallot, minced	1/3 loaf original Velveeta, cut into cubes
3 cups water	1/2 cup shredded mozzarella cheese
1/2 Tbsp seasoned salt	1 cup shredded cheddar cheese
1/2 Tbsp Worcestershire sauce	1/4 jar diced pickled jalapeños
1/2 Tbsp dry mustard	

#### **Directions**

- Follow the "**BROWNING**" instructions in this manual.
- Melt butter and sauté shallots for 2-3 minutes.
- Cancel "**BROWNING**" Add water, salt, Worcestershire sauce, dry mustard & pasta and cook under pressure for 1 minute.
- When the pressure cooker has finished the cooking cycle, follow the instructions in the "Removing Lid after Pressure Cooking" section of this manual.
- Open lid and add cheeses & jalapeños; stir well.
- Close lid and let cheese melt for 2-3 minutes, then stir again. *(For extra creamy "TV" Mac & cheese, stir in 2 cups whole milk, half & half or heavy cream at the end).*

Recipes are courtesy of [www.recipezaar.com](http://www.recipezaar.com) and [www.fastcooking.ca](http://www.fastcooking.ca).

Please note that all of the information is for your reference only and can be adjusted according to the user's preference.

### **BEEF IN PEPPER SAUCE**

SERVES 2-4

#### ***Ingredients***

##### **Pepper Sauce**

1/2 red bell pepper or green bell pepper  
 1/4 cup baby carrot  
 1/2 (8 ounce) can tomato sauce (1 tbsp to be use later)  
 1 garlic cloves  
 1 teaspoons ground ginger  
 1/2 teaspoon turmeric

1/2 teaspoon salt  
 1/4 teaspoon black pepper  
 1/2 teaspoon cayenne pepper (depends on how spicy you like it)  
 1/4 teaspoon ground cardamom  
 1 tablespoons olive oil

1 lb boneless sirloin steaks, cut into strips  
 salt & pepper  
 1/2 cup water  
 1/4 teaspoon paprika

1/2 teaspoon cumin  
 1/2 onions, sliced  
 1/2 green bell pepper, sliced

#### ***Directions***

- Remove 1 tablespoon of tomato sauce from the can to be used later. Blend the ingredients for the pepper sauce (green pepper through cardamom) in a food processor until there are no chunks left. Set aside.
- Follow the "**BROWNING**" instructions in this manual: add enough olive oil, sprinkle the beef with salt & pepper then brown in the cooker without the lid.
- Once browned, cancel "**BROWNING**" and add water, reserved tomato sauce, paprika & cumin to the beef. Close and lock the pressure cooker lid. Adjust the pressure valve on top to Airtight and press the **MEAT & CHICKEN** function switch.
- When the pressure cooker has finished the cooking cycle, follow the instructions in the "Removing Lid after Pressure Cooking" section of this manual.
- Add the pepper mixture, sliced onions & green peppers to the meat and sauce, close and lock lid and press the **MEAT & CHICKEN** function again.
- When the pressure cooker has finished the cooking cycle, follow the instructions in the "Removing Lid after Pressure Cooking" section of this manual.
- Vegetables and meat should be tender. Serve immediately over white rice if desired.

## CHICKEN PICCATA

SERVES 3

### *Ingredients*

3 chicken breast halves	1/2 cup pimento stuffed olive, minced
1/4 cup all-purpose flour	1/4 cup sour cream
2 tablespoons cup olive oil	1 tablespoon potato starch or flour
2 shallots	1/4 cup fresh parmesan cheese, grated
1 garlic cloves, crushed	1 tablespoon fontinella cheese, grated
1/2 cup chicken broth	1 lemon, thinly sliced, to garnish
1/4 cup fresh lemon juice	1 teaspoon dried basil
1/2 tablespoon sherry wine	
1 teaspoons salt	
1/4 teaspoon white pepper	

### *Directions*

- Lightly dust chicken pieces with flour.
- Follow the "**BROWNING**" instructions in this manual: heat oil. Add chicken breasts, two at a time, and sauté in hot oil until brown on all sides. Remove from inner pot and set on a paper towel lined dish.
- Add shallots and garlic to the inner pot and sauté for 3 to 5 minutes, scraping bottom of pan to loosen browned particles remaining from chicken. Stir in broth, lemon juice, sherry, salt, pepper, basil, and olives.
- Cancel "**BROWNING**."
- In the cooking pot, add chicken pieces skin side down back in.
- Close and lock the pressure cooker lid. Adjust the pressure valve on top to Airtight and press the **MEAT & CHICKEN** function switch.
- When the pressure cooker has finished the cooking cycle, follow the instructions in the "Removing Lid after Pressure Cooking" section of this manual.
- Stir chicken mixture, then transfer just the chicken to serving platter, and cover to retain heat.
- Whisk sour cream and starch together. Stir into cooking liquid inside the pressure cooker and cook over manual heat 1 minute, stirring constantly.
- Spoon sauce over chicken. Sprinkle with cheese and garnish with lemon slices.

## SPARE RIBS

SERVES 4

### *Ingredients*

1 cup brown sugar	1/4 teaspoon cayenne
1/4 cup soy sauce	1 teaspoon garlic powder
1/2 teaspoon paprika	2 lbs pork ribs
1 tablespoon vinegar	1 cup of chicken/beef stock

### *Directions*

- Prepare sauce ingredients inside cooking pot.
- Divide ribs up evenly so it fits into the pressure cooker.
- Coat each piece thoroughly with the sauce.

## RECIPES

- Place ribs into pressure cooker pot after coating with sauce.
- Add the 1 cup of stock to the bottom of pot.
- Close and lock the pressure cooker lid. Adjust the pressure valve on top to Airtight and press the **MEAT & CHICKEN** function switch.
- When the pressure cooker has finished the cooking cycle, follow the instructions in the "Removing Lid after Pressure Cooking" section of this manual.

### TRADITIONAL MEAT LOAF

SERVES 2-4

#### *Ingredients*

1 1/2 lb mixture of chopped or ground lean beef, pork and veal	1 medium onion, minced	1 garlic clove
Freshly ground pepper	1 egg	
2 slices bread, soaked in water and squeezed dry	2 tablespoons chicken stock	
1 teaspoon salt	1 cup tomato sauce	
2 tablespoons parsley	2 teaspoons Worcestershire sauce	
	1 cup water	
	2 tablespoons olive oil	

#### *Directions*

- In a bowl, combine the chopped meat, salt, pepper, bread, parsley, onion, garlic, egg, chicken stock and Worcestershire sauce. Shape into two small loaves. Wrap each in wax paper and chill several hours to firm.
- Follow the "**BROWNING**" instructions in this manual add the oil and brown the loaves well on all sides. Cancel "**BROWNING**." Remove and set on oven-safe dish (not included) that will fit into the pressure cooker.
- Pour out the oil and combine the tomato sauce and water, and season with salt and pepper. Spread the ketchup over the meat loaves and lower the oven-safe dish into the pressure cooker.
- Close and lock the pressure cooker lid. Adjust the pressure valve on top to Airtight and press the **MEAT & CHICKEN** function switch.
- When the pressure cooker has finished the cooking cycle, follow the instructions in the "Removing Lid after Pressure Cooking" section of this manual.
- Remove dish using a removing utensil/tool. Slice and serve immediately.



## JAMBALAYA

SERVES 4

### *Ingredients*

1 tablespoon vegetable oil	1/8 teaspoon cayenne pepper
1/2 lb boneless skinless chicken breasts, cut into 1" pieces	1/2 onion, chopped
1/2 lb fully cooked Andouille or Italian sausage, sliced	1 garlic cloves, minced
1/2 lb uncooked shrimp, peeled and deveined	1 green bell pepper, chopped
2 teaspoons Creole seasoning	1 stalks celery, sliced
1 teaspoon dried thyme leaves	1/2 cup long grain rice
	8 oz canned chopped tomatoes, un-drained
	1 cup chicken stock
	2 tablespoons fresh parsley, minced

### *Directions*

- Follow the "**BROWNING**" instructions in this manual, add oil and add chicken, sausage and shrimp. Sprinkle half of the Creole seasoning, half the thyme and half the cayenne. Cook for 3-5 minutes uncovered, stirring frequently, until chicken and shrimp are thoroughly cooked. Remove chicken, sausage and shrimp with a slotted spoon and set aside.
- Add onion, bell pepper, celery and remaining Creole seasoning, thyme and cayenne to skillet and cook for 4-5 minutes, stirring frequently.
- Add chicken, sauce, shrimp and rice, tomatoes with their juice and stock back into the pot. Cancel "**BROWNING**."
- Close and lock the pressure cooker lid. Adjust the pressure valve on top to Airtight and press the **SOUP & STEW** function switch.
- When the pressure cooker has finished the cooking cycle, follow the instructions in the "Removing Lid after Pressure Cooking" section of this manual.
- Serve with rice if desired.

## CORNISH HENS BRAISED IN WHITE WINE

SERVES 4

### *Ingredients*

12 tablespoons olive oil	1 tablespoon minced parsley
1 Cornish hen, trussed	1 tablespoon flour
1/2 teaspoon salt	1/2 cup dry white wine
1/4 teaspoon freshly ground black pepper	1/2 cup chicken stock
1/2 teaspoon thyme	1/4 lb mushrooms, cleaned and sliced
1/2 teaspoon basil	

### *Directions*

- Follow the "**BROWNING**" instructions in this manual heat the olive oil and brown the Cornish hens on all sides. Sprinkle them with salt and pepper, thyme, basil and parsley. Remove and set aside. Cancel "**BROWNING**."
- In the cooking pot, stir in the flour, and then pour in the wine and stock and add the hens back in.

## RECIPES

- Close and lock the lid and program the pressure cooker for 40-minutes.
- When the pressure cooker has finished the cooking cycle, follow the instructions in the "Removing Lid after Pressure Cooking" section of this manual.
- Serve with rice or a salad if desired.

---

Recipes courtesy of [www.peggyunderpressure.com](http://www.peggyunderpressure.com). Visit the website for more recipes!

### **SOUTHERN TANGY PULLED ROAST BEEF**

SERVES 4

#### ***Ingredients***

2-3 Lb. Chuck Roast	2 to 4 oz butter (half a stick or 1 stick)
1 Packet of Ranch Dressing Powder	1 Jar of Pepperoncinis
1 Packet of Au Ju Mix Powder	

#### ***Directions***

- Place about 4 peppers into bottom of the cooking pot first. Then place chuck roast on top of them. This will lift roast up off bottom of pan and prevent burning and overheating.
- Open packets of seasonings and sprinkle them both over top of the roast, covering as much as possible. Place a few more pepperoncinis on top of roast, and around it. Then pour about 1/4 to 1/2 of the pepperoncini liquid into the pot. Add 1/2 cup of water, put whole piece of butter directly on top of roast.
- Program the pressure cooker to cook for 60-minutes.
- When the pressure cooker has finished the cooking cycle, follow the instructions in the "Removing Lid after Pressure Cooking" section of this manual.
- You can serve this roast any way you like.

### **BALSAMIC CHICKEN AND ONIONS**

SERVES 4

#### ***Ingredients***

2 lbs. Chicken Thighs (You can use chicken breast to cut down on calories.)	1/2 Cup Dried Mixed Berries (You can use any kind, a mix or just golden raisins.)
1 Cup Chopped Carrots (Frozen or fresh, but don't use baby carrots)	1 Bay Leaves
1 Cups Pearl Onions (Frozen or fresh)	2 Cloves of Garlic
	1/2 Cup Balsamic Vinegar
	1/2 Cup Red Wine Vinegar

#### ***Directions***

- Season the chicken on both sides with salt and pepper. Then place ham hock and chicken into bottom of inner pot. Place all remaining ingredients into pot. The chicken will brown on the side touching the bottom of the pot.
- Close and lock the lid on your pressure cooker. Make sure the Pressure Valve is set to Airtight.

- Press **MEAT & CHICKEN** program button on your machine OR program the pressure cooker for 17-minutes.
- When the pressure cooker has finished the cooking cycle, follow the instructions in the "Removing Lid after Pressure Cooking" section of this manual.
- You'll notice that the level of liquids inside the pot has almost doubled. Use a pair of tongs and carefully remove the chicken. Set chicken aside and go back to the remaining sauce. Ladle out or pour out half of that liquid and return it back to the pressure cooker to reduce/thicken the sauce. Follow instructions in this manual for "**BROWNING**" Reduce the sauce so it becomes nice and thick. Help it along by adding flour or cornstarch if you like.
- Once the sauce is thickened to the desired consistency, cancel "**BROWNING**" and return chicken carefully back into the sauce.
- Set the pressure cooker to Keep Warm until ready to serve. Serve with rice or mashed potatoes.

### HAWAIIAN BBQ CHICKEN

SERVES 4

#### *Ingredients*

2lbs. Chicken (Frozen or Fresh; Breast, Thighs, Wings or Drumettes)  
 1/2 Cup BBQ Sauce  
 1 Cup Diced Pineapples (Canned or Fresh)

1/2 Cup Canned Coconut Milk  
 1/2 Tbsp Chili Flakes (Or more to taste)  
 Shredded Coconut (garnish)  
 Juice of Limes (garnish)

#### *Directions*

- Mix BBQ Sauce, Coconut Milk and Chili Flakes together.
- In main cooking pot of your pressure cooker, place the pineapples at the very bottom. This will be closest to the heat source and will render out the pineapple juice so the pressure cooker will use the juices to steam and pressurize since the BBQ sauce mixture is quite thick and may burn if you place it on the very bottom.
- Start dipping chicken pieces in the BBQ sauce mixture, a thin coat is fine.
- Add them into the pot one by one. Pour the remaining sauce mixture over the chicken when you're done. Shut the lid of the pressure cooker, turn to lock it.
- Set the pressure valve to Airtight. Program pressure cooker for 10-minutes.
- When the pressure cooker has finished the cooking cycle, follow the instructions in the "Removing Lid after Pressure Cooking" section of this manual. The chicken and pineapples will have released liquids during the pressure cooking process so there will be lots of liquid inside.
- Remove just the chicken with a pair of tongs and set aside temporarily. At this time, you can use a potato masher and mash down the pineapples so they become pulpier. (If you want the sauce extra thick, you can also make a roux with a bit of the liquid ladled out in a little bowl, mix a bit of flour with it until smooth and pour it back into the pot.)
- Once the sauce has thickened to your desired consistency, place the chicken back in. Now it's ready to serve with rice or on its own. Garnish with a healthy heap of shredded coconut and a squeeze of lime juice.

## ITALIAN POT ROAST

SERVES 4

### ***Ingredients***

2-lbs Beef Rump Roast (Cut into 2" chunks; you can choose to leave the roast whole, but cooking time will be 60-75 minutes)

1 8oz. Jar/Can of Roasted Red Bell Pepper

1 8oz. Jar/Can of Sun Dried Tomatoes

1 8oz. Jar/Can of Marinated Artichokes in Water

1 Whole Onion (Finely Sliced)

2 Whole Garlic (Minced)

1 Package of Mushrooms (Chopped)

1 Tbsp Italian Seasoning

### ***Directions***

- Remove the fat from the roast and use a sharp knife to cut the meat into large 2 inch chunks.
- Pre-cook the meat in the pressure cooker first to do a "wash". This removes all the unwanted fat and gristle from the meat so it leaves the end result cleaner.
- Place the meat into the pressure cooker and pour in 3-4 cups of water. Season with salt and pepper if you wish. Shut the lid and lock into position. Set the valve to AIRTIGHT and program pressure cooker for 10-minutes.
- When the pressure cooker has finished the cooking cycle, follow the instructions in the "Removing Lid after Pressure Cooking" section of this manual.
- Remove the meat into a bowl. Discard all the grimy water. Rinse the meat in the bowl to remove any remaining residue and then place back into the cooking pot of the pressure cooker again.
- Add the remaining ingredients in with the meat.
- Julienne the bell peppers and chop the artichokes. Leave the sun dried tomatoes as is unless they need chopping as well.
- Include the olive oil and water from the jars of bell peppers, sun dried tomatoes and artichokes. Do not drain. Pour them into the pressure cooker pot.
- Add the onions and mushrooms and garlic.
- Add the Italian Seasoning.
- Lock the lid and set the pressure cooker to cook for an additional 20-minutes.
- When the pressure cooker has finished the cooking cycle, follow the instructions in the "Removing Lid after Pressure Cooking" section of this manual.
- You can use the cooking juices from the cooking to make gravy.
- Use a slotted spoon and ladle out all the meat and vegetables, and put them into a separate serving platter. In a small bowl, mix half a cup of water with 1 tbsp of flour and mix until it becomes a runny white goo. Stir it while slowly pouring in the flour mixture and keep stirring and simmering until the gravy becomes a nice thick consistency.
- Serve your pot roast over mashed potatoes or some pasta or with a side of roasted potatoes. Top with the fresh gravy.

## **ST. PATRICK'S BANGERS AND MASH**

SERVES 2

### ***Ingredients***

4 Bangers (Sausages)	2 tablespoons Butter
3 Baking Potatoes (Peeled and Diced)	Salt & Pepper
1/2 Cup Milk	1/2 Whole Onion (Sliced into rings)

### **FOR THE POTATOES:**

1/4 Cup Sour Cream  
1/4 Cup Parmesan Cheese

### **OTHER EQUIPMENT:**

Potato Masher  
Sheet of Foil

### ***Directions***

- Peel and dice potatoes and place in bottom of pressure cooker pot. (You can leave the peels on, just scrub them real well if you do.)
- Lightly toss with salt and pepper.
- Add the cup of milk. Slice tabs of butter and place them over the potatoes. Carefully lay a sheet of foil over the potatoes and place sausages onto the foil and make sure they do not risk rolling off. Top the sausages with onions. (You can also choose to pre-brown the sausages slightly to give it a nice golden color.)
- Close lid and secure into place. Adjust the pressure valve to "AIRTIGHT" and program the pressure cooker for 20-minutes.
- When the pressure cooker has finished the cooking cycle, follow the instructions in the "Removing Lid after Pressure Cooking" section of this manual.
- Remove the sausages in the foil. You'll notice that the sausages are cooked but look grey.
- Now onto the potatoes. Start mashing them carefully with a potato masher directly inside the pressure cooker pot - avoid scratching the non-stick of the inner pot.
- Add more milk, salt or butter if you prefer to get potatoes to desired consistency.
- To serve, you can choose to slice the sausages or leave them whole.

## **APPLES AND ONION PORK TENDERLOIN**

SERVES 4

### ***Ingredients***

2-3 lb. Pork Rump or Pork Tenderloin	1 Cup Apple Juice
1 Apples (Sliced)	1/2 Cup Broth (Chicken, Beef or Vegetable)
1/2 Whole Onion (Sliced)	Salt & Pepper to taste
1 Bay Leaves	

### ***Directions***

- Remove any unwanted fatty pieces from pork. Season with salt and pepper on both sides.
- Place onions and apples into cooking pot. Pour in apple juice and broth.
- Place the pork rump directly into pot. Shut the lid and turn it to lock it into place.
- Make sure Pressure Valve is set to Airtight.
- Program pressure cooker for 60-minutes.
-

- When the pressure cooker has finished the cooking cycle, follow the instructions in the "Removing Lid after Pressure Cooking" section of this manual.
- The onions and apples should melt as soon as you stir them. The pork is super juicy and tender. Slice into thick slices and serve over mashed potatoes or stuffing and ladle on the apple and onion gravy.

### ITALIAN POTATO, RICE, & SPINACH SOUP

SERVES 4

#### *Ingredients*

2 tablespoons olive oil	1 tablespoons fresh lemon juice
3 leeks, white part only, sliced	2 tablespoons tomato paste
1 garlic cloves, crushed	1/2 tablespoon light brown sugar
1 carrot	6 ounces fresh spinach, rinsed, cut in large pieces
1/4 cup Arborio rice	2 tablespoons parmesan cheese, grated
1 potatoes, cut in large chunks	2 tablespoons fontinella cheese, grated
3 cups chicken stock	1 teaspoon dried basil
2 tablespoons parsley, chopped	1/4 teaspoon pepper
1/4 cup celery, chopped	
1 bay leaf	
1/2 teaspoon salt	

#### *Directions*

- Follow the "**BROWNING**" instructions in this manual and heat oil. Add leeks, garlic, and carrots and sauté in hot oil for 2 minutes. Cancel "**BROWNING**."
- Add rice and potatoes. Stir well.
- Add broth, parsley, celery, bay leaf, salt, pepper, basil, lemon juice, tomato paste and brown sugar. Stir well.
- Close and lock the pressure cooker lid. Adjust the pressure valve on top to Airtight and press **SOUP & STEW**.
- When the pressure cooker has finished the cooking cycle, follow the instructions in the "Removing Lid after Pressure Cooking" section of this manual.
- Ladle the soup into large serving bowl or individual bowls.
- Combine the cheeses and sprinkle over soup. Serve with Italian bread.

## SOUTH OF THE BORDER SPICY CHILI

SERVES 2-4

Chili is a nutritionally sound and complete meal. You can make it more or less fiery by adjusting the amount of chili powder used.

### **Ingredients**

1 tablespoons olive oil	1 bay leaf
1 medium onion, chopped	1 teaspoons celery seed
1 garlic cloves, minced	Salt to taste
1 lb ground beef	1/2 tablespoon flour
1teaspoons ground cumin	1 cup crushed tomato
1 tablespoons chili powder, or to taste	1/2 cup beef stock
1 teaspoons oregano	1 cups cooked pinto or red kidney beans

### **Garnishes**

Grated cheddar or Monterey Jack cheese  
 Finely chopped onion  
 Shredded lettuce

### **Directions:**

- Follow the "**BROWNING**" instructions in this manual: heat oil and sauté the onion and garlic until onion is wilted.
- Add beef and cook until browned. Mix cumin, chili powder, oregano, bay leaf, celery seed, salt and flour. Stir in crushed tomato and beef stock. Cancel "**BROWNING.**"
- Add the beans.
- Close and lock the pressure cooker lid. Adjust the pressure valve on top to Airtight and press the **BEANS & GRAINS** function switch.
- When the pressure cooker has finished the cooking cycle, follow the instructions in the "Removing Lid after Pressure Cooking" section of this manual.
- Serve chili in bowls, passing the garnishes separately.

## SAUSAGE AND LENTIL SOUP

SERVES 2-4

### **Ingredients**

2 Cups Dried Lentils	1 Bay Leaves
1 Cups Chopped Sausage (any sausage to your liking)	1 Tbsp Beef Bouillon (Or 2 Cups Beef Broth)
1 Cup Crushed Roasted Tomatoes	3 Cups Fresh Water (Less or more depending on the size of your pressure cooker.)
1/2 Cup Mirepoix (chopped mixture of celery, carrots and onions.)	Salt & Pepper to taste
2 Garlic cloves, minced	

### **Directions**

- Follow the "**BROWNING**" instructions in this manual: sauté the mirepoix and garlic until they are fragrant. Cancel "**BROWNING.**"Add remaining ingredients into the cooking pot. Shut lid
-

and lock properly into position. Adjust the Pressure Valve to "Airtight". Program pressure cooker for 15-minutes.

- When the pressure cooker has finished the cooking cycle, follow the instructions in the "Removing Lid after Pressure Cooking" section of this manual.
- Since it's a big pot of soup, there may be some spitting at the pressure valve when you turn it to exhaust. Sometimes a folded up dish rag or towel over the valve will help.
- Give the soup a good stir. It may appear a bit watery but depending on if you want to keep it more on the brothy side or you want to thicken it a bit, you can thicken it by mixing a bit of the broth liquid with flour until it becomes a thick roux and pour the roux back into the soup and stir it. Season with salt and pepper to your preference. Serve with a dollop of sour cream or plain greek yogurt.

### KIELBASA, BUTTERNUT SQUASH & KALE SOUP

SERVES 2

#### *Ingredients*

1/2 Package Kielbasa Sausage (Chopped into half-moon size)  
 2 Cups Chicken Broth  
 1 Cup Chopped Butternut Squash  
 1 Sprig of Fresh Rosemary  
 1/2 Onion, Chopped

1 Cup Fresh Kale  
 2 Cloves Garlic, Minced  
 Water  
 1/2 Shot Glass Sherry, Cooking Wine or White Wine  
 1/2 Cup Wild Rice

#### *Directions*

- Follow the "**BROWNING**" instructions in this manual: add a bit of olive oil and place the first 4 ingredients in and sauté for 4 minutes. Pour in shot glass of cooking wine or sherry and sauté for another 2-3 minutes. Cancel "**BROWNING**."
- Add the wild rice and chicken broth. Depending on how much soup you want, you can fill up the rest of the pot with water and add in the sprigs of fresh Rosemary. **Do not add the Kale into the soup yet.**
- Close and lock pressure cooker lid. Set Pressure Valve to "Airtight" and program the pressure cooker for 10-minutes.

**Note:** If you are making a really large, almost full pot, the pressure cooker will take quite a while to heat up everything inside and come to pressure, about 20 to 30-minutes to build up pressure. Once the pressure has been reached the 10-minutes will begin to count down. Once the 10-minutes have reached 0, the cooker will automatically beep and go to keep warm.

- When the pressure cooker has finished the cooking cycle, follow the instructions in the "Removing Lid after Pressure Cooking" section of this manual.
- Since it's a big pot of soup, there may be some spitting at the pressure valve when you turn it to exhaust. Sometimes a folded up dish rag or towel over the valve will help.
- Give everything a good stir. When the soup is ready to serve, you can add the kale and let the heat of the soup cook it just slightly. It will take less than a minute. Add salt and pepper to taste as you serve.



## SPLIT PEA & HAM-HOCK SOUP

SERVES 2

### *Ingredients*

1 Cup of Dried Split Peas	1/2 Cup Chopped Potatoes
1 Small-Medium Ham Hock	1/2 Cup Chopped Carrots
1/4 Cup Chopped Yellow Onion	1/2 Cup Chopped Ham or Smoked Sausage
1/4 Cup Chopped Celery	3 Cups of Water or Chicken Stock
1 Cloves of Finely Chopped Garlic	

### **SPECIAL EQUIPMENT:** Immersion Hand Blender

- Follow the "**BROWNING**" instructions in this manual: add a bit of olive oil and sauté the onions, celery and garlic for a few minutes. Cancel "**BROWNING**."
- Add Split Peas to the vegetable mixture.. Take the Ham Hock and use a sharp knife to carefully cut a few slits into the chunk, but don't slice it all the way through. Add to mixture in pot. Pour water into pot so water overlaps the mixture of Split Peas by 2 inches. You can choose to use chicken stock if you like. You can do a mixture of water and stock as well.
- Shut lid and lock it. Adjust valve to Airtight. Program the pressure cooker for 15-minutes.
- When the pressure cooker has finished the cooking cycle, follow the instructions in the "Removing Lid after Pressure Cooking" section of this manual.
- The Split Peas will have mostly disintegrated. Using a pair of tongs, remove Ham Hock from soup and set aside. You'll need to put it back in later.
- **(Optional)**. Use an Immersion Hand Blender in the soup mixture. Give it a few pulses to blend the soup into a smooth creamy texture. Now add the chopped carrots, potatoes and ham to the soup. Add salt and pepper.
- Place Ham Hock back in and shut the lid. (Don't let the soup sit idle for too long because it will thicken as it sits and keeps warm. If it becomes too thick, add water or chicken stock.)
- Program pressure cooker to cook for another 5-minutes.
- If the soup mixture is too thick, the machine might have a hard time building up pressure because the thick mixture might be over-heating at the bottom of the pot. If this happens, the machine will just beep fairly soon and put itself on Keep Warm. Leave the machine alone. It will have built up enough pressure in that time so just let it sit and drop down in pressure automatically. The carrots and potatoes are cut up small enough that it should cook fairly quickly.
- When the pressure cooker has finished the cooking cycle, follow the instructions in the "Removing Lid after Pressure Cooking" section of this manual.
- When the soup is finished, serve while it's hot with some butter toast or croutons.

## FISHERMAN'S SEAFOOD CHOWDER

SERVES 2

### *The Soup Base Ingredients*

#### **A Mild Roux Mix**

1 Tbsp Flour

1 Tbsp Butter

1 Cup White Wine

### *The Stock & Other Ingredients*

1 Cup Water

1 Cup Chicken Stock

1/2 Whole Onion (Chopped)

1 Whole Tomatoes (Chopped)

1/2 Cup Corn (Optional)

1/4 Cup Celery (Optional)

2 Cloves of Garlic (Chopped)

1/2 Can Tomato Sauce

1 Bay Leaves

1/2 Tsp Saffron Strands

### *Directions*

- To make a roux, follow the "**BROWNING**" instructions in this manual: melt the butter and then add the flour to the butter and mix with a wooden spoon. Start diluting the roux with the white wine little by little.
- To the roux mix, add the chopped onions, garlic and chopped tomatoes, plus the celery. Cook the mixture for just a couple of minutes and then cancel "**BROWNING**." The mixture should be thick and creamy. Season with salt and pepper.
- Add the water, tomato sauce and chicken stock. Add bay leaves and saffron. Give everything a good mix. The soup base should be pretty watery with a slight hint of thickness. If it's still too thick, add more water or stock or white wine.

### **SEAFOOD INGREDIENTS**

1/2 Cup Seafood Mix (Calamari Rings,  
Scallops, Bay Shrimps, etc.)

1/2 Cup Whole Clams

1/2 Cup Whole Shrimp (Shells removed)

1/2 Cup Chopped Salmon (Or any other fish  
is fine)

- Add the seafood to the soup base mix. You always want to leave at least about 2-inches from the top rim to prevent over-flowing. (If you like, you can remove the shells so there is more room.)
- Once the seafood has been added, give everything another good stir. Then shut lid and turn to lock it into position. Adjust Pressure Valve to "Airtight".
- Program the pressure cooker for 10-minutes.
- When the pressure cooker has finished the cooking cycle, follow the instructions in the "Removing Lid after Pressure Cooking" section of this manual.
- Serve with slices of sourdough bread or crackers.

## LEEK & ASPARAGUS RISOTTO

SERVES 2

### *Ingredients*

1 1/2 tablespoons olive oil	1 1/2 cups Arborio rice
1 1/2 tablespoons butter	4 cups vegetable broth
1 1/2 tablespoons water	1/4 lb asparagus, chopped into 1 inch segments
2 garlic cloves, minced	1 1/4 cups parmesan cheese, shredded
1 1/2 cups leeks, sliced	

### *Directions*

- Follow the "**BROWNING**" instructions in this manual: heat the olive oil and butter.
- Add the garlic and leeks, sauté until soft then cancel "**BROWNING**."
- Add rice, stir thoroughly and then add broth.
- Close and lock pressure cooker lid. Adjust pressure valve to Airtight and press **RICE**.
- While risotto cooks, steam asparagus in water. Then sauté in olive oil. Season with salt and pepper.
- When the pressure cooker has finished the cooking cycle, follow the instructions in the "Removing Lid after Pressure Cooking" section of this manual.
- Serve immediately or the risotto will become thicker and thicker as it sits.

## CHICKEN NOODLE

SERVES 2-4

### *Ingredients*

2 boneless skinless chicken thighs	1 sprig fresh sage
1 carrots, large dice	1 teaspoon poultry seasoning
1/2 onion, chopped	salt and pepper, to taste
1 stalks celery, finely diced	1/2 lb egg noodles, frozen such as Reames brand
1 garlic cloves, chopped	1/2 cup frozen peas
3 cups chicken stock	1 tablespoon stock
1 bay leaf	1 lemon, juice of
2 sprigs fresh thyme	1 tablespoon cup parsley, chopped
1 sprig fresh rosemary	

### *Directions*

- Follow the "**BROWNING**" instructions in this manual: saute onion, celery and garlic until lightly browned. Cancel "**BROWNING**." Add chicken, carrot, chicken stock, bay leaf, herbs & seasonings.
- Close and lock pressure cooker lid. Adjust pressure valve to Airtight.
- Program to cook for 10 minutes. Allow pressure to naturally release.
- Open pressure cooker lid when safe to do so.
- Add frozen egg noodles, close and lock pressure cooker lid. Adjust pressure valve to Airtight and program to cook 3 minutes.
- When the pressure cooker has finished the cooking cycle, follow the instructions in the "Removing Lid after Pressure Cooking" section of this manual.
- Remove sprigs of fresh herbs. Add peas & chopped parsley for color and juice of 1 lemon. Stir and serve.

## PRESSURE COOKER CORN ON THE COB

SERVES 4

### *Ingredients*

4 ears sweet corn, halved

2 cups water

### *Directions*

- Pour the water in the bottom of your pressure cooker pot.
- Arrange the corn in pot standing up.
- Secure the lid and set the Valve to Airtight. Press **STEAM** button.
- When the pressure cooker has finished the cooking cycle, follow the instructions in the "Removing Lid after Pressure Cooking" section of this manual.

## CREAM OF GARDEN TOMATO SOUP

SERVES 2-4

### *Ingredients*

1 tablespoon vegetable oil

1/2 teaspoon salt

1 tablespoon butter

1/4 teaspoon black pepper, freshly ground

1 small onion, finely chopped

1/2 cup chicken broth (or vegetable broth or water)

1 lb tomatoes, coarsely chopped

1/2cup heavy cream

1 teaspoons fresh thyme, chopped

### *Directions*

- Follow the "**BROWNING**" instructions in this manual: heat oil and butter in the pressure cooker until butter melts. Add the onion and cook, stirring occasionally, until wilted, about 5 minutes.
- Cancel "**BROWNING**."
- Add tomatoes and their juices, thyme, salt, pepper, and broth and stir to mix.
- Lock on the lid and set Valve to Airtight. Press **STEAM** button.
- When the pressure cooker has finished the cooking cycle, follow the instructions in the "Removing Lid after Pressure Cooking" section of this manual.
- Use an immersion blender to puree soup (or transfer soup to blender or food processor and puree in smaller batches to avoid burning yourself).
- If after blending you see any chunks of tomato peel, put soup through strainer or food mill to remove.
- If using right away, place soup in large pan and stir in cream. Reheat gently without boiling then add garnish of choice and serve.
- If not using right away, store in the refrigerator until ready to use; then stir in the cream, heat and serve.

## **BROWN RICE**

SERVES 4-6

### ***Ingredients***

4 cups water	3 dashes Mrs. Dash seasoning mix, original
2 cups long brown rice	3 tablespoons butter
4 chicken bouillon cubes	pepper

### ***Directions***

- Add all ingredients to Inner Pot.
- Lock on the lid and set Valve to Airtight. Press **RICE** button.
- When the pressure cooker has finished the cooking cycle, follow the instructions in the "Removing Lid after Pressure Cooking" section of this manual.
- Remove and serve.

## **BABY BACK RIBS – FAST & EASY**

SERVES 2-3

### ***Ingredients***

3 lbs beef back ribs	1/4 teaspoon paprika
1/2 teaspoon salt	2 tablespoons olive oil
1/4 teaspoon black pepper	1 cup beer
1/2 teaspoon onion powder	12 ounces barbecue sauce
1/4 teaspoon garlic powder	

### ***Directions***

- Cut ribs into serving pieces.
- Mix spices together to create a dry rub. Apply the dry rub to the ribs.
- Follow the "**BROWNING**" instructions in this manual: heat oil and brown the ribs on all sides. Cancel "**BROWNING**."
- Add beer. Close and lock lid securely, set the Valve to Airtight.
- Press **MEAT & CHICKEN** button.
- When the pressure cooker has finished the cooking cycle, follow the instructions in the "Removing Lid after Pressure Cooking" section of this manual.
- Add barbecue sauce and serve immediately.

## **POT ROAST WITH MUSHROOM GRAVY**

SERVES 4-6

### ***Ingredients***

2 lbs chuck roast, 2-3 inches thick	2 (10 3/4 oz) cans cream of mushroom soup
2 tablespoons vegetable oil	1 cup water (or beef or chicken stock)
1 envelope onion soup mix	

### ***Directions***

- Follow the "**BROWNING**" instructions in this manual: brown meat on all sides in oil.
- Mix all other ingredients and add to pot, coating meat. Cancel "**BROWNING**."

- Close and lock lid securely, set the Valve to Airtight.
- Program the pressure cooker to cook 50-60 minutes.
- When the pressure cooker has finished the cooking cycle, follow the instructions in the "Removing Lid after Pressure Cooking" section of this manual.
- Thin gravy with beef stock or thicken to your own taste.

### CHICKEN STOCK

#### *Ingredients*

2 lb chicken parts, primarily backs, but also including gizzards, necks, hearts and wings	2 sprigs parsley
1 medium onion, peeled and halved	6 peppercorns or 1/4 teaspoon ground black pepper
1 celery stalk, cut in several pieces	1 teaspoon thyme
1 large carrot, scraped and cut in several pieces	2 bay leaves
	Salt to taste
	6 cups water

#### *Directions:*

- Combine all ingredients in the pressure cooker's inner pot.
- Close and lock lid securely, set the Valve to Airtight.
- Program Pressure Cook Time for 45 minutes.
- When the pressure cooker has finished the cooking cycle, follow the instructions in the "Removing Lid after Pressure Cooking" section of this manual.
- Strain by pouring it through a strainer which has been lined with a couple of layers of damp cheesecloth, damp kitchen towel or damp paper towels. Press with the back of a wooden spoon to extract as much liquid as possible. Cool, then refrigerate overnight and remove any congealed fat that has collected on the surface.

### OLD FASHIONED MEAT LOAF

SERVES 4

#### *Ingredients*

1 1/2 lb mixture of chopped or ground lean beef, pork and veal	1 garlic clove
1 teaspoon salt	1 egg
Freshly ground pepper	2 tablespoons chicken stock
2 slices bread, soaked in water and squeezed dry	2 teaspoons Worcestershire sauce
2 tablespoons parsley	2 tablespoons olive oil
1 medium onion, minced	1 cup tomato sauce
	1 cup water

#### *Directions*

- In a bowl, combine the chopped meat, salt, pepper, bread, parsley, onion, garlic, egg, chicken stock and Worcestershire sauce.
- Shape into two small loaves. Wrap each in wax paper and chill several hours to firm.
- Follow the "**BROWNING**" instructions in this manual: heat oil and brown the loaves well on all sides. Cancel "**BROWNING**."

## RECIPES

- Transfer to the cooker basket.
- Pour off the oil and combine the tomato sauce and water, and season with salt and pepper.
- Spread the ketchup over the meat loaves and lower the basket into the pot.
- Close and lock lid securely, set the Valve to Airtight.
- Set Pressure Cook Time to 25 minutes.
- When the pressure cooker has finished the cooking cycle, follow the instructions in the "Removing Lid after Pressure Cooking" section of this manual.
- Slice and serve immediately.

### TOMATO PASTA SAUCE

SERVES 2-3

#### *Ingredients*

3 tablespoons canola oil	3 teaspoons dried basil
1/2 cup onion, finely chopped	2 teaspoons dried oregano
3/4 cup carrot, finely chopped	1 teaspoon dried parsley
3/4 cup celery, finely chopped	1 or 2 bay leaves
2 garlic cloves, minced	1/4 cup dry red or white wine
1 large can crushed canned tomatoes	1/2 cup water
1/4 cup tomato paste	Salt and freshly ground pepper, to taste

#### *Directions*

- Follow the "**BROWNING**" instructions in this manual: heat the oil and sauté the onion, carrot, celery and garlic until they are softened. Cancel "**BROWNING**."
- Add all the remaining ingredients. Close and lock lid securely, set the Valve to Airtight. Press **STEAM** button.
- When the pressure cooker has finished the cooking cycle, follow the instructions in the "Removing Lid after Pressure Cooking" section of this manual.
- Reduce the sauce if it is not thick enough.

### POTATO AND GREEN BEAN CASSEROLE

SERVES 4

#### *Ingredients*

3 potatoes, peeled and cut in 1" cubes	1 green pepper, diced
3/4 lb green beans	1 tablespoon minced parsley
1 tablespoon olive oil	Salt and freshly ground pepper
1 medium onion, minced	1/2 cup chicken stock
1 garlic clove, minced	

#### *Directions*

- Add all ingredients to the inner pot. Close and lock lid securely, set the Valve to Airtight.
- Program Pressure Cook Time to 7 minutes.
- When the pressure cooker has finished the cooking cycle, follow the instructions in the "Removing Lid after Pressure Cooking" section of this manual.
- Serve and Enjoy.

## LEMON CHICKEN

SERVES 4

### *Ingredients*

3 1/2 lb chicken cut into serving pieces	2 teaspoons oregano
1/4 cup plus 2 tablespoons olive oil	Salt and freshly ground pepper to taste
1/4 cup lemon juice	1/2 cup chicken stock

### *Directions:*

- In a small bowl, mix together 1/4 cup oil, lemon juice, oregano, salt and pepper. Pour over the chicken and marinate for several hours, or overnight.
- Dry the chicken well on paper towels and sprinkle with salt and pepper. Reserve the marinade.
- Follow the "**BROWNING**" instructions in this manual: heat the remaining 2 tablespoons oil and brown the chicken pieces on all sides. Cancel "**BROWNING**."
- Reserve chicken pieces on warm platter. Pour off the fat and add to the inner pot the reserved marinade and the chicken stock.
- Close and lock lid securely, set the Valve to Airtight.
- Press **MEAT & CHICKEN** button.
- When the pressure cooker has finished the cooking cycle, follow the instructions in the "Removing Lid after Pressure Cooking" section of this manual.
- Serve the chicken with the sauce spooned over it.

## OLD FASHIONED BAKED BEANS

SERVES 4

### *Ingredients*

2 cups dry navy beans (also called white beans or pea beans)	2 fl oz (1/2 small can) tomato paste
3 tablespoons oil	3 tablespoons brown sugar
1 large onion, diced	2 tablespoons molasses
1 clove garlic, minced	1/2 teaspoon prepared mustard
1 3/4 cups water	1/4 teaspoon cumin
	1/8 teaspoon chili powder

### *Directions*

- Rinse and then soak the beans in water for about 8 hours.
- You can begin soaking them in the morning so they will be ready to cook at suppertime.
- Drain the soaking water after the beans are hydrated.
- Add all ingredients except the beans to the inner pot and stir. Then add the beans.
- Close and lock lid securely, set the Valve to Airtight.
- Press the **BEANS & GRAINS** button.
- When the pressure cooker has finished the cooking cycle, follow the instructions in the "Removing Lid after Pressure Cooking" section of this manual.
- Serve with whole wheat bread.



## RECIPES

### MACARONI PUTTANESCA

SERVES 4-5

#### **Ingredients**

1 16oz jar of puttanesca, marinara or your favorite sauce	1/2 bell pepper, diced (any color)
1 8oz box of macaroni (or any type of pasta)	1 clove garlic, minced
1/2 bag of frozen meatballs	salt & pepper
1/2 onion, diced	Olive oil for browning

#### **Directions:**

- Remove lid. Start browning function. Add oil to inner pot. Add onion, bell pepper and garlic to inner pot.
- Stir while browning. Season with salt & pepper.
- Keep browning until onions are caramelized.
- Add jar of sauce, box of macaroni, and frozen meatballs to inner pot.
- Add 1-1.5 cups of water to inner pot. Place lid onto pressure cooker and lock into place.
- Set pressure limiting valve to "Airtight."
- Program to cook for 3-6 minutes.
- When the pressure cooker has finished the cooking cycle, follow the instructions in the "Removing Lid after Pressure Cooking" section of this manual.
- Remove and serve.

## DESSERTS

### APPLESAUCE

Makes about 4 1/2 cups

#### **Ingredients**

3 lb apples, peeled, cored, and quartered	Optional: Grated lemon zest
3/4 teaspoon ground cinnamon	Optional: Fresh lemon juice
1/3 cup water or apple juice	Optional: Honey

#### **Directions**

- Place the apples, cinnamon, and water (or juice) into pot.
- Close and lock lid securely, set the Valve to Airtight.
- Press **STEAM** button.
- When the pressure cooker has finished the cooking cycle, follow the instructions in the "Removing Lid after Pressure Cooking" section of this manual.
- You can serve the applesauce chunky, or puree it in a food processor.
- Prior to serving, if desired, stir in the lemon zest, lemon juice, and honey to taste.
- Serving Suggestion: Top warm applesauce topped with some raisins and chopped, toasted walnuts.

**ORANGE-FLAVORED CANDIED YAMS**

SERVES 4

***Ingredients***

- |                               |                               |
|-------------------------------|-------------------------------|
| 1 cup orange juice            | 1/2 cup brown sugar           |
| 2 large sweet potatoes (yams) | 1 teaspoon grated orange zest |
| Salt, to taste                | 2 tablespoons butter          |

***Directions***

- Pour orange juice into pressure cooker. Peel sweet potatoes and cut them in half lengthwise. Arrange in a pressure cooker steamer basket (not included) and sprinkle with salt, brown sugar and orange zest. Dot with butter.
- Lower steamer basket into pressure cooker.
- Close and lock the pressure cooker lid. Adjust the pressure valve to Airtight and program the pressure cooker for 25 minutes.
- When the pressure cooker has finished the cooking cycle, follow the instructions in the "Removing Lid after Pressure Cooking" section of this manual.
- Lift out the sweet potatoes.
- Boil down the sauce until thickened and pour over the sweet potatoes.

**OLD FASHIONED RICE PUDDING**

SERVES 4

***Ingredients***

- |                         |                         |
|-------------------------|-------------------------|
| 1 tablespoon butter     | 1 egg                   |
| 1/4 cup long grain rice | 1/4 cup evaporated milk |
| 2 cups milk             | 1/2 teaspoon vanilla    |
| 1 cup water             | Cinnamon                |
| 1/3 sugar               | 1/2 teaspoon salt       |

***Directions:***

- Follow "**BROWNING**" instructions in this manual: Melt butter and stir in rice, coating it with the butter. Pour in fresh milk and water, and stir in sugar and salt. Cancel **BROWNING**.
- Close and lock lid and program the pressure cooker for 10-minutes.
- When the pressure cooker has finished the cooking cycle, follow the instructions in the "Removing Lid after Pressure Cooking" section of this manual.
- In a small bowl mix together the egg, evaporated milk and vanilla. Stir in a little of the hot liquid from pressure cooker, then add mixture to the pressure cooker.
- Cover again and set to cook for 5 more minutes.
- When the pressure cooker has finished the cooking cycle, follow the instructions in the "Removing Lid after Pressure Cooking" section of this manual.
- Cool 10 minutes, stirring occasionally.
- Transfer to individual dessert bowls, continue cooling, then refrigerate. Serve sprinkled with cinnamon.

**PEARS STEWED IN RED WINE**

SERVES 2-3

***Ingredients***

2 cups water	2-3 firm pears, peeled but not cored, stems on
1/2 cup sugar	3/4 cup red wine
2 slices lemon	1 cup frozen raspberries
2 cinnamon sticks	4 tablespoons heavy cream
1/4 teaspoon mace	

***Directions:***

- Follow the "**BROWNING**" instructions in this manual: combine the water, sugar, lemon, cinnamon sticks and mace. Simmer until sugar is dissolved.
- Cancel **BROWNING**.
- Place pears into pressure cooker cooking pot, trimming bottoms if necessary so they stand upright. Add liquid from the saucepan.
- Close and lock lid and program the pressure cooker for 10-minutes.
- When the pressure cooker has finished the cooking cycle, follow the instructions in the "Removing Lid after Pressure Cooking" section of this manual.
- Add the red wine.
- Lock lid in place again and program to cook for 10 more minutes.
- When the pressure cooker has finished the cooking cycle, follow the instructions in the "Removing Lid after Pressure Cooking" section of this manual.
- Carefully remove only the pears and transfer to a deep container.
- Boil down the remaining sauce until it is syrup. Cool, then pour over the pears and keep at room temperature overnight.
- To serve, defrost and purée the raspberries in a processor until smooth.
- Spoon 4 tablespoons of the purée on four dessert dishes or shallow bowls. Place a pear upright in the center of each dish. Spoon some syrup over the pears.
- Dribble 1 tablespoon of cream in a circle over the sauce. With the aid of a knife, swirl the cream into the sauce in an attractive design and serve.

**CINNAMON APPLE FLAN WITH MAPLE SYRUP**

SERVES 4

***Ingredients***

5 tablespoons maple syrup	1/4 teaspoon vanilla
1/4 teaspoon cinnamon	6 tablespoons sugar
2 apples, peeled and cut in 1/4" slices	2 1/2 cups milk
3 whole eggs 3 egg yolks	

***Directions:***

- Follow the "**BROWNING**" instructions in this manual: combine the maple syrup and the cinnamon. Add the apple slices and slowly simmer until the apples are tender.
- Divide the mixture into 6 greased oven-safe custard cups (not included). In a large bowl, whisk eggs and egg yolks. Stir in vanilla, sugar and milk. Pour mixture slowly into the custard cups. Cover tightly with foil.
-

## DESSERTS

- Fill the pressure cooker cooking pot with 2 1/2 cups water. Place as many custard cups as will fit in the pressure cooker steamer basket (if available) and lower into pressure cooker.
- Close and lock lid and program the pressure cooker for 10-minutes.
- When the pressure cooker has finished the cooking cycle, follow the instructions in the "Removing Lid after Pressure Cooking" section of this manual.
- Remove the lid, take out the basket, loosen the foil and cool the custard.
- Refrigerate. To serve, loosen the custard from the molds with a knife and invert onto dessert dishes.

### COCONUT RICE PUDDING

SERVES 4

#### **INGREDIENTS:**

1 Cup Arborio Rice	1/2 Tsp Freshly Ground Cloves
2 Cups Coconut Milk (Unsweetened)	1 Whole Vanilla Bean
1 Cup Almond Milk (Unsweetened)	3 Strips Orange Zest Strip
2 Cinnamon Sticks	1 Can Sweetened Condensed Milk

#### **Directions:**

- Follow the "**BROWNING**" instructions in this manual: add all liquid ingredients (except the condensed milk). Add spices to the mixture. Leave cinnamon sticks and orange zest strips whole. Using a knife, gently slice a long slit down the middle of the vanilla pod. Scrape the vanilla bean into the pot and swish it around. Add the whole vanilla pod also and bring the whole mixture to a light simmer. Cancel **BROWNING**.
- Add rice and give it a quick stir. Close lid and turn to lock into place. Adjust the Pressure Valve to Airtight. Program the pressure cooker for 15-minutes. Use "Natural Release" to allow pressure to naturally release.
- When the pressure cooker has finished the cooking cycle, follow the instructions in the "Removing Lid after Pressure Cooking" section of this manual.
- Press the CANCEL button to turn off the Keep Warm feature. Remove cinnamon sticks, orange zest and vanilla pod and discard.
- Open two cans of Sweetened Condensed Milk and add to the rice pudding and stir. Allow to cool slightly, then cover and place into refrigerator to cool completely.
- Serve warm or cold with a drizzle of honey if desired. Garnish with sliced strawberries, blueberries, orange zest or nutmeg.

### ITALIAN MEATBALLS

SERVES 4

#### *Ingredients*

1 lb. ground beef	1/2 lb. Italian sausage
2 eggs	1/4 C. milk
1/2 C. dry breadcrumbs	3 Tbsp. grated parmesan cheese
1/2 tsp. garlic powder	salt and pepper

#### *Directions*

- In a bowl, beat eggs and add milk. Add beef and Italian sausage. Mix together.
- Add rest of ingredients and mix until combined.
- Shape the mixture into 1 inch balls and place on a greased cookie sheet.
- Bake at 350°F for 15 minutes.
- Add to pressure cooker.

#### **Sauce**

1 8 oz. can tomato sauce	1 6 oz. can tomato paste
1 small onion chopped	1/2 C. green pepper
1/2 C. beef broth	1/3 C. water
1 garlic cloves minced	1 tsp. oregano
1 tsp. salt	1 tsp. sugar
1 2 tsp. pepper	

#### *Directions*

- Mix all ingredients in a bowl and pour over the meatballs.
- Program to **SLOW COOK** for 4 - 5 hours.

### SLOPPY JOES

SERVES 4

#### *Ingredients*

2 lbs. ground beef	1 C. onions diced
1 C. celery diced	1 C. green pepper diced
1 1/2 C. ketchup	2 Tbsp. Worcestershire sauce
1 6 oz. can tomato paste	3/4 C. water
1/2 tsp. paprika	3 Tbsp. vinegar
3 Tbsp. brown sugar	1 tsp. dry mustard
salt and pepper	

#### *Directions*

- Brown ground beef in the pressure cooker by following the **BROWNING** instructions.
- Add the rest of the ingredients and mix well.
- Program to **SLOW COOK** for 8 hours. Serve on hamburger buns.

### CHILI DIP

SERVES 2-3

#### *Ingredients*

1 lb. ground beef	1 16 oz. jar mild picante sauce
1 8oz. can refried beans	8 oz. sour cream
1/2 tsp. chili powder	1/2 C. chopped onion
8 oz. cheddar cheese shredded	Jalapenos or mild chilies to taste

#### *Directions*

- Brown ground beef and onion in the pressure cooker by following the **BROWNING** instructions.
- Drain and add back to pressure cooker. Add beans, picante sauce, jalapenos (if using) and chili powder.
- Program to **SLOW COOK** for 2 - 3 hours. Add cheese and sour cream last 1/2 hour.
- Serve with tortilla chips.

### WILD MUSHROOM BEEF STEW

SERVES 3-4

#### *Ingredients*

2 lbs. beef for stew, cut into 1-inch pieces	1/4 C. all-purpose flour
1 tsp. salt	1/2 tsp. pepper
1/2 tsp. dried thyme leaves, crushed	3/4 C. ready-to-serve beef broth
1/4 C. tomato paste	1/4 C. dry red wine
2 cloves garlic, minced	1 lb. red-skinned potatoes (1-1/2-inch diameter), cut into quarters
8 oz. assorted mushrooms, such as shiitake, cremini and oyster, cut into quarters	
1 C. baby carrots	Fresh parsley (optional)

#### *Directions*

- Combine flour, salt, pepper and thyme in small bowl. Place beef into pressure cooker. Sprinkle with flour mixture; toss to coat.
- Combine broth, tomato paste, wine and garlic in small bowl; mix well. Add to beef. Add potatoes, mushrooms and carrots; mix well.
- Program to **SLOW COOK** for 8 to 9 hours, or until beef and vegetables are tender. (No stirring is necessary during cooking.) Stir well before serving. Garnish with parsley, if desired.

## SLOW COOKER RECIPES

### POT ROAST

SERVES 4

#### *Ingredients*

3 lb. pot roast	large onion cut up
1 C. beef broth	1 lb. carrots cut in 2 inch pieces
4 - 5 potatoes diced	salt and pepper

#### *Directions*

- Brown pot roast in the pressure cooker by following the **BROWNING** instructions. Once browned, remove pot roast from inner pot.
- Add vegetables to the pressure cooker. Top with roast and pour beef broth over it. Salt and pepper to taste.
- Program to **SLOW COOK** for 8 hours.

### BBQ MEATLOAF

SERVES 4

#### *Ingredients*

2 lbs. ground beef	3/4 C. barbecue sauce
1 egg	1 C. crushed soda crackers
2 tsp. Worcestershire sauce	1/2 C. diced onion
1/2 tsp. salt	1/4 C. water
2 tsp. prepared mustard	2 Tbsp. brown sugar
1 Tbsp. vinegar	

#### *Directions*

- Mix all ingredients in a large bowl. Form into a meatloaf shape that will fit into your pressure cooker. Cut a strip of foil to go under the meatloaf in the pressure cooker, leaving it long enough so that you can use it to lift the meatloaf out when it is finished cooking.
- After placing the meatloaf in pressure cooker, top the meatloaf with an additional 1/3 C. barbecue sauce. Program to **SLOW COOK** for 8 - 9 hours.

### CHICKEN MERLOT WITH MUSHROOMS

SERVES 4

#### *Ingredients*

2 1/2 to 3 lbs. boneless, skinless chicken thighs	12 oz. sliced fresh mushrooms
1 garlic cloves, peeled and minced	1 large onion, peeled and chopped
1 6-oz. can tomato paste	3/4 C. low-sodium chicken broth
2 Tbsp. quick-cooking tapioca	1/4 C. Merlot or any dry red wine, or additional chicken broth
2 Tbsp. chopped fresh basil	2 tsp. granulated sugar
1/4 tsp. salt	1/4 tsp. freshly ground black pepper
2 C. cooked noodles	2 Tbsp. freshly grated Parmesan cheese

## SLOW COOKER RECIPES

### **Directions**

- Rinse chicken, pat dry and set aside.
- Place the mushrooms, onion and garlic in the pressure cooker. Place the chicken pieces on top of the vegetables.
- Combine broth, tomato paste, wine, tapioca, dried basil (if using), sugar, salt and pepper in a medium bowl. Pour mixture over the chicken and vegetables.
- Program to **SLOW COOK** for 7 to 8 hours.
- To serve, spoon chicken mixture over cooked noodles. Sprinkle with Parmesan cheese.

### **CHICKEN WINGS IN HONEY SAUCE**

SERVES 2-3

#### **Ingredients**

3 pounds chicken wings (16 wings)	salt and pepper to taste
2 cups honey	1 cup soy sauce
1/2 cup ketchup	1/4 cup oil
2 cloves garlic, minced	

#### **Directions**

- Rinse chicken and pat dry. Cut off and discard wing tips. Cut each wing at joint to make two sections. Sprinkle wing parts with salt and pepper.
- Place wing parts on broiler pan. Broil 5-4 inches from heat 20 minutes, 10 minutes a side or until chicken is brown. Transfer chicken to pressure cooker.
- For sauce, combine honey, soy sauce, ketchup, oil and garlic in bowl. Pour over chicken wings.
- Program to **SLOW COOK** for 4-5 hours.

### **SOUTHWESTERN CHICKEN**

SERVES 4

#### **Ingredients**

1 (8-oz) can whole kernel corn, drained	1 (11- oz) can Mexicorn, drained
1 (8- oz) can black beans, rinsed and drained	1 (16- oz) jar chunky salsa (divided use)
4 boneless, skinless chicken breast halves, rinsed and dried	
Flour tortillas	Shredded cheddar cheese

#### **Directions**

- Combine the cans of corn, beans and half the salsa in pressure cooker. Top with the chicken. Pour remaining sauce over.
- Program to **SLOW COOK** for 9.5 hours or until meat juices run clear. Serve with warm tortillas; top with cheese.



### CHICKEN PAPRIKA WITH DUMPLINGS

SERVES 4-6

#### **Ingredients**

4 boneless, skinless chicken breasts	1 medium onion chopped
1 tsp. salt	1/2 tsp. black pepper
1 Tbsp. Hungarian paprika	1 cup chicken broth
8 ounces sour cream	1 Tbsp. cornstarch or flour

#### **Dumpling Ingredients:**

3 eggs	1/3 cup water
2-1/2 cups all-purpose flour, sifted	

#### **Directions**

- Add onions to pressure cooker. Add seasonings, chicken and broth.
- Program to **SLOW COOK** for 5 to 6 hours.
- Shortly before serving, stir together sour cream and cornstarch. Follow **BROWNING** instructions and stir mixture into pressure cooker and heat through.
- Taste and adjust seasonings (sour cream and cornstarch may be omitted if desired). Serve with dumplings (recipe below)

#### **Dumplings Instructions**

- Beat 3 eggs, add 1/3 cup water and 2-1/2 cups flour. Beat with a spoon until smooth.
- Drop from teaspoon into boiling salted water and cook until dumplings rise to the top, approximately 10 minutes.

### CHEESY SHRIMP PASTA

SERVES 3

#### **Ingredients**

1 (2-lb.) block Velveeta cheese	1 (16-oz.) carton half-and-half
1 (8-oz) Canned Chopped Tomatoes	1 small onion, chopped
3 cloves garlic, minced	1 lb. raw shrimp
Cooked pasta of choice	

#### **Directions**

- Place cheese, half-and-half, tomatoes, onion and garlic in pressure cooker. Program to **SLOW COOK** for 4 hours.
- Add shrimp and **SLOW COOK** for another 90 minutes or until shrimp are pink.
- Cook pasta of choice and spoon sauce over cooked pasta.

### SALMON BAKE

SERVES 3

#### *Ingredients*

2 cans salmon, boned and skinned (15 oz. size)	4 cups bread crumbs
1 tsp. lemon juice	1 (8-oz.) can tomatoes
1 chopped green bell pepper	1 (8-oz.) can cream of onion soup
1 can cream of celery soup	4 well beaten eggs
1 tsp. garlic powder	1 teaspoon Greek seasoning
2 chicken bouillon cubes, crushed	1/4 cup milk

#### *Directions*

- Combine all ingredients except celery soup and milk. Pour into pressure cooker. Program to **SLOW COOK** for 5 hours.
- Combine cream of celery soup with 1/2 cup of milk and heat in saucepan. Use as a sauce for salmon bake.

### BAKED STUFFED APPLES

SERVES 6

#### *Ingredients*

6 medium red tart apples	1 C. light brown sugar
1/4 C. raisins	1 Tbsp. orange peel
1/4 C. butter	2 C. very hot water
3 Tbsp. orange juice concentrate	

#### *Directions*

- Wash and core the apples, but don't peel them. In a pan that will fit in your pressure cooker, stand the apples up. Butter the pan first.
- Fill the core cavities with the brown sugar, raisins and orange peel. Top with butter.
- Place the pan in the pressure cooker. Pour the hot water around the pan. Sprinkle the orange juice concentrate over the apples.
- Program to **SLOW COOK** for 3 - 5 hours or until apples are tender.

### PIÑA COLADA BREAD PUDDING

SERVES 4

#### ***Ingredients***

1 lb. loaf French bread	10 oz. frozen piña colada drink mix
6 oz. pineapple juice	12 oz. evaporated milk
1/2 C. cream of coconut	2 large bananas; sliced
3 eggs	1/4 C. light rum
1 C. raisins	8 oz. pineapple; crushed w/juice
1 t. lemon peel; grated	fresh mint sprigs

#### ***Directions***

- With a sharp knife, peel crust from bread; discard crust or make into bread crumbs for use in another recipe. Cut bread into 1-inch cubes; set aside. In blender or food processor, fitted with a metal blade, combine 1/2 of the following ingredients; drink mix, pineapple juice, evaporated milk, cream of coconut, and banana slices.
- Process until pureed; pour puree into a 6-cup bowl. Puree remaining 1/2 of liquid ingredients and banana slices as well as eggs and liqueur, if desired.
- Combine both purees; set aside. Combine raisins and crushed pineapple (and the juice); set aside.
- Place about 2/3 of bread cubes in pressure cooker, sprinkle with 1/2 t. grated lemon peel and spread 1 cup of the raisin-pineapple mixture over bread in pressure cooker. Top with remaining bread cubes, then with remaining 1/2 t. lemon peel and raisin-pineapple mixture.
- Pour pureed ingredients into pressure cooker.
- Program to **SLOW COOK** for 6 hours. Spread pudding into 8 or 10 dessert dishes and serve hot. Garnish with fresh mint sprigs.

### BLUEBERRY BUMP CAKE

SERVES 6

#### ***Ingredients***

2 21 oz. cans blueberry pie filling	2 packages yellow cake mix
1 C. butter	1 C. chopped walnuts

#### ***Directions***

- Place pie filling in the pressure cooker. Combine dry cake mix and butter, sprinkle over filling. Sprinkle the walnuts on top of that. Program to **SLOW COOK** for 2 - 3 hours. Serve warm in bowls.
- Top with whipped cream or vanilla ice cream.

**LIMITED WARRANTY\* ONE (1) YEAR**  
**WARRANTY IS ONLY VALID WITH A DATED PROOF OF PURCHASE**

**PLEASE DO NOT RETURN TO STORE.**

**If you have any problems with this unit, contact Consumer Relations for service**

1. Your small kitchen appliance is built with precision, inspected and tested before leaving our factory.
2. It is warranted to the original purchaser to be free from any manufacturing defects under normal use and conditions for one (1) year, cord excluded. This Warranty applies only to the original purchaser of this product.
3. Retail stores/merchants selling this product do not have the right to alter, modify, or in any way revise the terms and conditions of the warranty.
4. If you use your appliance for household use and according to instructions, it should give you years of satisfactory service.
5. At its sole discretion, Maxi-Matic USA will either repair or replace the product found to be defective during the warranty period.
6. The repaired or replacement product will be in warranty for the remaining balance of the one-year warranty period and an additional one-month period.
7. Consumer's remorse is not an acceptable reason to return a product to our Service Center.
8. **This limited warranty covers appliances purchased and used within the 50 U.S. states plus the District of Columbia and does NOT cover normal wear of parts or:**
  - Damages caused by unreasonable use, neglect, normal wear and tear, commercial use, improper assembly or installation of product.
  - Damages caused in shipping.
  - Damages caused by replacement or resetting of house fuses or circuit breakers.
  - Defects other than manufacturing defects.
  - Breakage caused by misuse, abuse, accident, alteration, lack of proper care and maintenance, or incorrect current or voltage.
  - Lost or missing parts of the product. Parts will need to be purchased separately.
  - Damages of parts that are not electrical; i.e. cracked or broken plastic/glass, scratched/dented inner pots.
  - Damage from service or repair by unauthorized personnel.
  - Extended warranties purchased via a separate company or reseller.
  - Acts of God such as fire, floods, hurricanes, tornadoes, etc.

Maxi-Matic, USA shall not be liable for any incidental or consequential damages caused by the breach of any express or implied warranty. Apart from the extent prohibited by applicable law, any implied warranty of merchantability or fitness for a particular purpose is limited in time to the duration of the warranty.

\*One Year Limited Warranty valid only in the **50 U.S. states plus the District of Columbia, excluding** Puerto Rico and the Virgin Islands.

This warranty is effective only if the product is purchased and operated in the USA; product usage which is in violation of the written instructions provided with the unit will void this warranty.

This warranty gives you special legal rights and you may also have other rights to which you are entitled which may vary by state, province, and/or jurisdiction.

For international warranty, please contact the local distributor.

\*\*Any instruction or policy included in this manual may be subject to change at any time.

***MAXI-MATIC, USA***

18401 E. Arenth Ave. City of Industry, CA 91748

Customer Service Dept: (626) 912-9877 Ext: 120/107/105/115 MON-FRI 8:30am-5pm PST

Visit: [www.maxi-matic.com](http://www.maxi-matic.com) for Live Chat Support and Contact Us Form

## RETURN INSTRUCTIONS

### RETURNS:

- A. Any return of defective merchandise to the manufacturer must be processed accordingly by first contacting customer service (info@maxi-matic.com) to obtain an RA # (Return Authorization Number). We will not accept any returns of merchandise without an applicable RA #.
- B. **IMPORTANT RETURN INSTRUCTIONS.** Your Warranty depends on your following these instructions if you are returning the unit to Maxi-Matic, USA:
  1. Carefully pack the item in its original carton or other suitable box with sufficient cushioning to avoid damage in shipping.
  2. Before packing your unit for return, be sure to enclose:
    - a) Your name, full address with zip code, daytime telephone number, and RA#,
    - b) A dated sales receipt or PROOF OF PURCHASE,
    - c) The model number of the unit and the problem you are having (Enclose in an envelope and tape directly to the unit before the box is sealed,) and
    - d) Any parts or accessories related to the problem.
  3. Maxi-Matic, USA recommends that you ship the package via UPS ground service for tracking purposes. **We cannot assume responsibility for lost or damaged products returned to us during incoming shipment.** For your protection, always carefully package the product for shipment and insure it with the carrier. C.O.D shipments cannot be accepted.
  4. **All return shipping charges must be prepaid by you.**
  6. Once your return has been received by our warehouse, Maxi-Matic, USA will repair or replace the product if it is defective in material or workmanship, subject to the conditions in paragraph B.
  7. **Maxi-Matic will pay the shipping charges to ship the repaired or replacement product back to you.**



P L A T I N U M

## Elite Customer Service Center

Mail: Maxi-Matic, USA  
18401 E. Arenth Ave  
City of Industry, CA  
91748-1227

Phone: 800-365-6133 ext. 120/107/105

Website: [www.maxi-matic.com](http://www.maxi-matic.com)  
Visit our website for Live Chat Support  
& Contact Us Form



[elitebymaximatic](https://www.facebook.com/elitebymaximatic)



[@elite\\_by\\_maximatic](https://www.instagram.com/elite_by_maximatic)

Elite is a registered trademark of Maxi-Matic, USA.  
Copyright Elite by Maxi-Matic.

Actual product may vary from the images/illustrations in this manual due to continual product improvement.

MODEL: EPC-414(A~Z)